

**SIYI**

---

# **HM30**

## **FULL HD TRANSMISSION SYSTEM USER MANUAL**



**SIYI Technology (Shenzhen) Co., Ltd.**

[siyi.biz/en](http://siyi.biz/en)

# SIYI

Thank you for purchasing SIYI product.

HM30 is an integrated transmission system developed by SIYI Technology, leveraging its fully self-developed low-latency wireless HD video transmission technology. It offers a communication range of up to 20 kilometers and supports dual-channel HD digital video transmission. With powerful performance and a comprehensive set of features, it also provides an optional dual-operator mode. Equipped with extensive interface options and strong scalability, HM30 is widely applicable to drones, unmanned vehicles and vessels, as well as intelligent robotics.

To ensure you a good experience of the product, please read this manual carefully. If you encounter any issue using the product, please consult the manual or check the online pages of this product on SIYI official website (<https://siyi.biz/en>). You can also write an email to SIYI official A/S center ([support@siyi.biz](mailto:support@siyi.biz)).

# SIYI

Contact Us: **SIYI Official Website** (<https://siyi.biz/en>)

SIYI User Group - Facebook	
Facebook	
LinkedIn	
YouTube	

# SIYI

## Manual Version Update Record

Version	Date	Updates
1.3	2024.1	<ol style="list-style-type: none"><li>1. Necessary update for product introduction.</li><li>2. Necessary update for SIYI FPV app.</li><li>3. User manual update log.</li><li>4. Main firmware update log.</li><li>5. SIYI FPV app update log.</li><li>6. Necessary update for technical specification.</li><li>7. Necessary update for packing list.</li><li>8. Necessary update for “Important Instructions on Promotion to Communication Range and Video Fluency”.</li><li>9. Necessary update for “Settings”.</li><li>10. Instruction in “Datalink” for connection to multiple GCS.</li></ol>
1.4	2024.3	<ol style="list-style-type: none"><li>1. Diagram image for connecting HM30 ground unit to LAN-HDMI converter.</li></ol>
1.5	2025.2	<ol style="list-style-type: none"><li>1. Remove the 42-kilometer image transmission mode in section 3.1.9.</li><li>2. Remove all content related to wireless relay.</li><li>3. Remove all content related to remote control relay.</li><li>4. Corrected some errors.</li></ol>
1.6	2025.4	Partial Revision of the "Dual Control with a Single Aircraft" Section
1.7	2026.3	Fix some known issues.

## CONTENTS

READ TIPS .....	9
Icons .....	9
Safety .....	9
Battery .....	12
Storage / Carrying / Recycling .....	12
CHAPTER 1 INTRODUCTION .....	14
1.1 Product Features .....	14
1.2 Parts .....	17
1.2.1 Overview .....	17
1.2.2 Channels .....	20
1.2.3 Data Stream Diagram .....	21
1.2.4 OLED Function Display .....	23
1.3 Technical Specification .....	23
1.4 Packing List .....	28
1.5 Indicator Definition .....	28
1.5.1 Ground Unit Indicator .....	29
1.5.2 Air Unit Indicator .....	30
CHAPTER 2 GET READY TO USE .....	32
2.1 Ground Unit .....	32
2.1.1 Power On / Off .....	32
2.1.2 Charging .....	32
2.1.3 Charging Indicator .....	33
2.2 Important Instructions on Promotion to HM30 Communication Range and Video Fluency .....	34
2.2.1 General Precautions .....	34
2.2.2 General Antenna Options and Wireless Mode Configuration for Different Range	35
2.2.3 How to Place the Standard Omni Antennas on Ground Unit .....	37
2.2.4 How to Place the Long-Range Patch Antennas on Ground Unit .....	38
2.2.5 How to Place Air Unit Antennas .....	38

# SIYI

2.2.6 The Communication Range Is Not as Expected and You Need Factory Support, Here Are the Necessary Information We Need .....	43
CHAPTER 3 MENU SETTINGS .....	45
3.1 GENERAL .....	46
3.1.1 Air Unit Number .....	47
3.1.2 Bind .....	48
3.1.3 RC Signal Input .....	49
3.1.4 Datalink Mode .....	51
3.1.5 Datalink Baud Rate .....	53
3.1.6 AAT (Antenna Tracker) Baud Rate .....	55
3.1.7 Failsafe .....	56
3.1.8 RSSI Channel .....	58
3.1.9 Wireless Mode .....	59
3.2 Video Output .....	61
3.3 VIDEO .....	63
3.4 DATALINK .....	64
3.5 Device Information .....	65
3.6 Mavlink Information .....	66
3.7 Multiple Links .....	66
3.8 Air Unit PWM Channels .....	69
CHAPTER 4 DATALINK .....	70
4.1 Communication with GCS via Bluetooth .....	70
4.1.1 QGroundControl .....	70
4.1.2 Mission Planner .....	73
4.2 Communication with GCS under UDP Protocol through the Ground Unit LAN Port ..	74
4.2.1 QGroundControl .....	74
4.2.2 Mission Planner .....	76
4.3 Output Datalink to Antenna Tracker through UART .....	78
4.4 Communication with Windows GCS through Type-C .....	79
4.4.1 QGroundControl .....	79
4.4.2 Mission Planner .....	80
4.5 Solutions to Disconnection .....	82

# SIYI

4.6 SIYI Datalink SDK .....	83
CHAPTER 5 SIYI FPV APP .....	96
5.1 Settings .....	98
5.2 Link Status .....	99
5.3 Gimbal Camera .....	100
5.4 About SIYI FPV .....	103
5.5 SIYI FPV App Update Log .....	104
5.6 SIYI FPV SDK Guide .....	105
5.6.1 Access Method .....	105
5.6.2 Interface Instructions .....	108
5.7 SIYI FPV SDK Update Log .....	111
CHAPTER 6 IMAGE TRANSMISSION .....	112
6.1 Enable AI Recognition & Tracking through SIYI AI Tracking Module Using SIYI Optical Pod (Gimbal Camera) and SIYI Link .....	112
6.2 Control SIYI Optical Pod (Gimbal Camera) in SIYI FPV App or SIYI QGC App through SIYI link .....	115
6.2.1 Preparation .....	116
6.2.2 Gimbal Pitch and Yaw Rotation .....	118
6.2.3 Zoom and Focus .....	118
6.2.4 Take pictures and Record Video .....	118
6.3 Control SIYI Optical Pod (Gimbal Camera) in SIYI QGC (Windows) Software through SIYI Link .....	119
6.3.1 Preparation .....	120
6.3.2 Gimbal Pitch and Yaw Rotation .....	122
6.3.3 Zoom and Focus .....	122
6.3.4 Take pictures and Record Video .....	123
6.4 Control SIYI Optical Pod (Gimbal Camera) by S.Bus Signal and Forward S.Bus Signal to Flight Controller through SIYI Link .....	123
6.4.1 Preparation .....	124
6.4.2 Gimbal Pitch and Yaw Rotation (Taking an example of Dial Control) .....	127
6.4.3 Zoom (Taking an Example of Switch Control) .....	128
6.4.4 Take Pictures and Record Video (Taking an Example of Button Control) .....	128

# SIYI

6.5 Connect Third-Party Ethernet Cameras to SIYI Link .....	129
6.6 Connect HDMI Cameras to SIYI Link .....	130
6.7 Connect Dual Video Stream to SIYI Link .....	131
6.7.1 Dual SIYI Cameras or Dual SIYI Air Unit HDMI Input Converters .....	131
6.7.2 Dual Third-Party Ethernet Cameras .....	131
6.7.3 SIYI HDMI Converter and Third-Party Ethernet Camera .....	131
6.8 Common IP Addresses .....	132
6.9 Solutions to No Image .....	134
6.10 Output Video Stream from Ground Unit .....	135
6.10.1 Through LAN Port .....	135
6.10.2 Through LAN to HDMI Output Converter .....	137
CHAPTER 7 SIYI ASSISTANT .....	138
7.1 Firmware Update .....	139
7.2 Main Firmware Update Log .....	142
7.3 SIYI Assistant Update Log .....	144
CHAPTER 8 AFTER-SALE SERVICE .....	146

# SIYI

## READ TIPS

### Icons

Please pay more attention to content indicated with the following marks:



**DANGER** Dangerous manipulation probably leads to human injuries.



**WARNING** Warnings on manipulation possibly leads to human injuries.



**CAUTION** Cautions on what manipulation may lead to property loss.



**Prohibited**



**Mandatory**



**Mark**

### Safety

HM30 transmission system is designed and manufactured for professional application scenarios. Operators need to have certain basic skills, so please use it with caution. SIYI Technology does not assume any responsibility for any unnecessary product damage caused by irregular or irresponsible operation of this product, economic losses or even personal injury to the user or others. Minors must have professionals present to supervise and guide minors when using this product. SIYI Technology's

# SIYI

products are designed for commercial use, and it is prohibited to use SIYI products for military purposes. It is prohibited to disassemble or modify this product without SIYI Technology's permission.

To jointly maintain flight safety and allow you to better utilize the features of this product, please pay special attention to the following matters:

 It is prohibited to operate in crowded places (squares, parks, etc.), places with many obstacles (streets, parking lots, etc.), places with strong magnetic fields or signal interference sources (high-voltage lines, railway lines, radar stations, etc.) or other places that may cause using SIYI products to control aircraft, vehicles or models in areas where unnecessary economic losses or even personal injuries will occur.

 During operation, never cover the ground unit antenna or otherwise block signal transmission.

 The top orientation of standard omni-directional antennas on ground unit is the weakest part for signal transmission. Avoid pointing the top orientation at your aircraft, vehicle, or model during missions.

 It is prohibited to use SIYI products to control aircraft, vehicles, or models when you are tired, drunk, or unwell.

 It is not wise to use SIYI products to control aircraft, vehicles, or models in rainy days, at night or against strong wind.

# SIYI

 When engines or motors are still running, do not cut off ground unit power.

 For flight safety, please keep the aircraft within line of sight during missions.

 Be sure to return to the main page from any system settings page during missions.

 Before missions, be sure to check the power supply of ground unit and air unit.

 After missions, cut the air unit power first, then the ground unit.

 Before configuring ground unit, make sure that the engines and motors are on no power to prevent accidental start.

 Before missions, make sure that the fail-safe function is configured on the radio controller or on the ground station software.

 When you are assembling the aircraft or vehicle, please avoid mounting the air unit too close to GPS module in case of interference. Reasonable distance between the air unit and GPS module should be longer than 20 cm.

# SIYI

## Battery

HM30 ground unit is compatible NP-F550 / F570 / F950 series high capacity chargeable li-ion battery which are commonly used for photography devices.

Please do read the precautions below before using.

 The ground unit cannot be charged when it is powered on. Before charging, please turn off the ground unit.

 If you find that the battery is smoking, overheating, or bulging, please stop using it immediately and contact your reseller or SIYI after-sales service center directly.

 If the battery overheats (above 60 degrees Celsius), please stop using it immediately and cut off the power supply.

## Storage / Carrying / Recycling

When the SIYI product you own is idle, or you want to take the SIYI product out for work, or the product has reached the end of its service life, please pay special attention to the following matters:

### **DANGER**

When SIYI products are not in use, they should be kept away from areas easily accessible to children.

# SIYI

Please avoid placing SIYI products in an environment that is too hot (above 50 degrees Celsius) or too cold (below minus 10 degrees Celsius).

## **CAUTION**

Please avoid placing SIYI products in humid or sandy environments.

When carrying and transporting SIYI products, please avoid operations that may damage components such as vibration or impact.

## CHAPTER 1 INTRODUCTION

### 1.1 Product Features

#### 20 KM Wireless Digital Image Transmission

##### Dual-Channel Full HD Video Stream

The link of HM30 is based on SIYI's independent wireless HD image transmission technology, which is an all-in-one link integrated with remote control, datalink, and video streaming. The technology has a smart feature that the transmission can automatically adapt to the frequency channel with least interference.

*\*With standard omni antennas, the transmission range is up to 15 kilometers.*

*\*With directional antennas, the transmission range is up to 20 kilometers.*

*\*To experience the lowest latency, it is suggested to use MK32 with SIYI FPV app (choosing SIYI camera protocol) or SIYI QGC app (integrated SIYI camera protocol).*

##### OSD Telemetry Display

The HM30 link supports to display data telemetry and OSD information display based on the Mavlink protocol in SIYI FPV app. The OSD display style can be adjusted, and combined with high-definition image transmission, you can enjoy the endless fun of first-person view.

# SIYI

## **Dual Operator, Efficient Collaboration**

Targeting popular industry application fields, relying on wireless high-definition image transmission technology, SIYI has given the HM30 link the feature of dual operator.

The "dual operator" function is developed for dual-operator scenarios and supports up to two ground units to establish links with the same air unit at the same time. One can be used to control the flight attitude of the drone, and the other can be used to control the gimbal camera, optical pod, and other payloads. In dual operator mode, two ground units can simultaneously acquire images from the same camera source or display images from different camera sources separately.

## **OLED Display & Configuration**

HM30 ground unit is equipped with an OLED display, which can display the link transmission status in real time and support quick parameter setting, making field flight missions more efficient and convenient.

## **Quick Release Battery, PD Fast Charging**

HM30 ground unit supports quick-release battery power supply, and users can choose NP-F550 / 750 / 950 series film industry standard batteries.

# SIYI

When equipped with a quick-release battery, the ground unit supports up to 30W PD fast charging protocol.

HM30 ground unit also supports external power battery power supply, ensuring long-time operation.

# SIYI

## 1.2 Parts

### 1.2.1 Overview



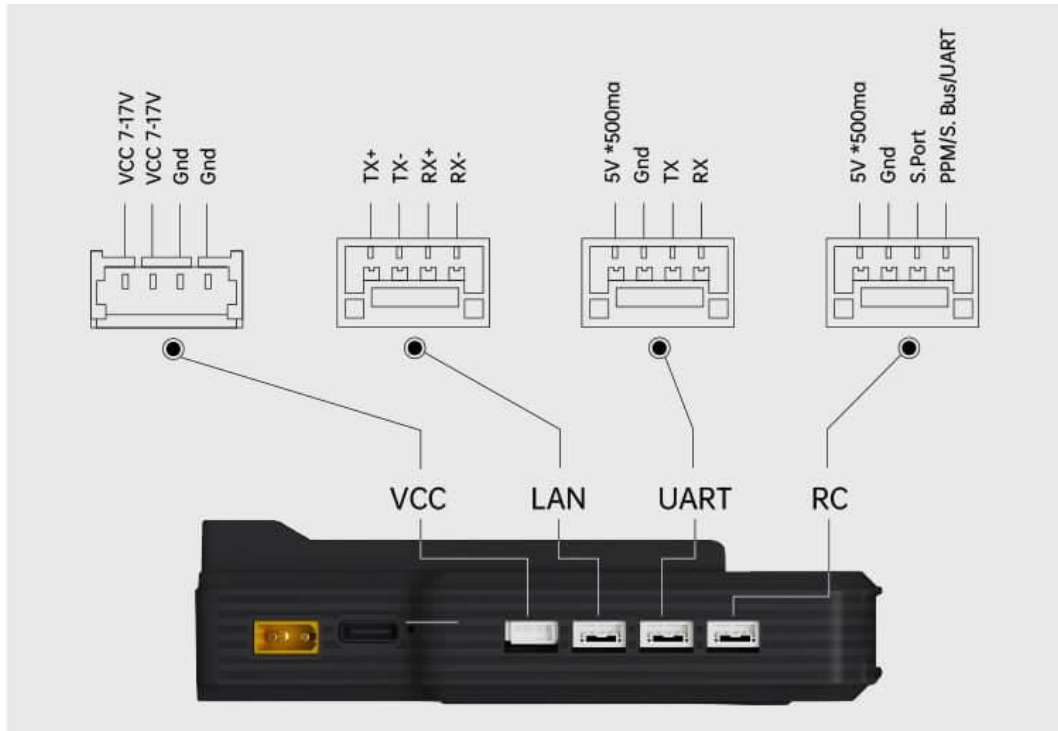

**Ground Unit Interface & Pinouts**

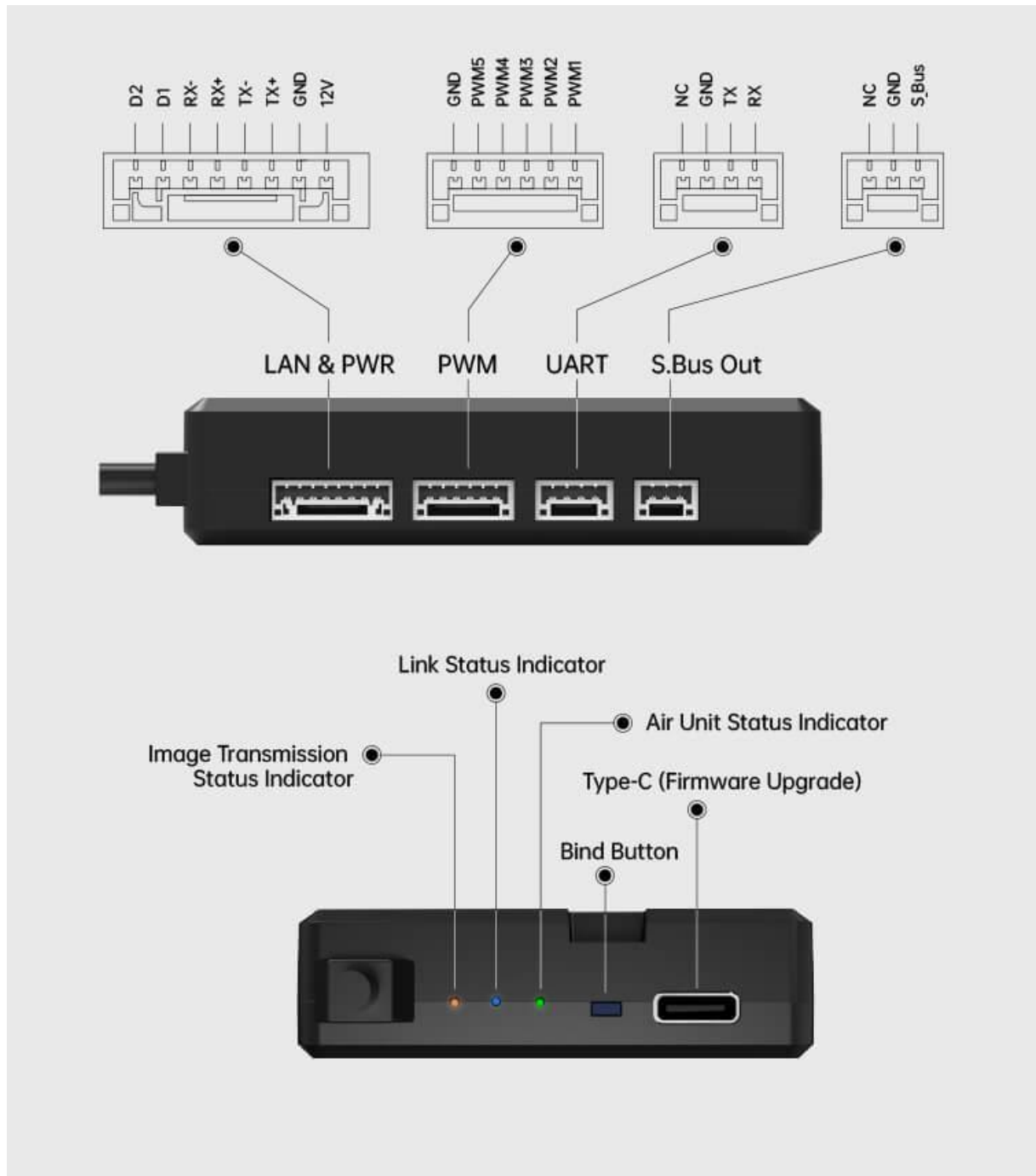

## Air Unit Interface & Pinouts

### Note

Welcome to contact SIYI to get the SIYI Air Unit 3D Model for pre-installation.

# SIYI

## 1.2.2 Channels

HM30 supports up to 16 communication channels in total. Channel 10 to 14 are mapped to PWM channels 1 to 5 in default.

## 1.2.3 Data Stream Diagram

### Ground Unit

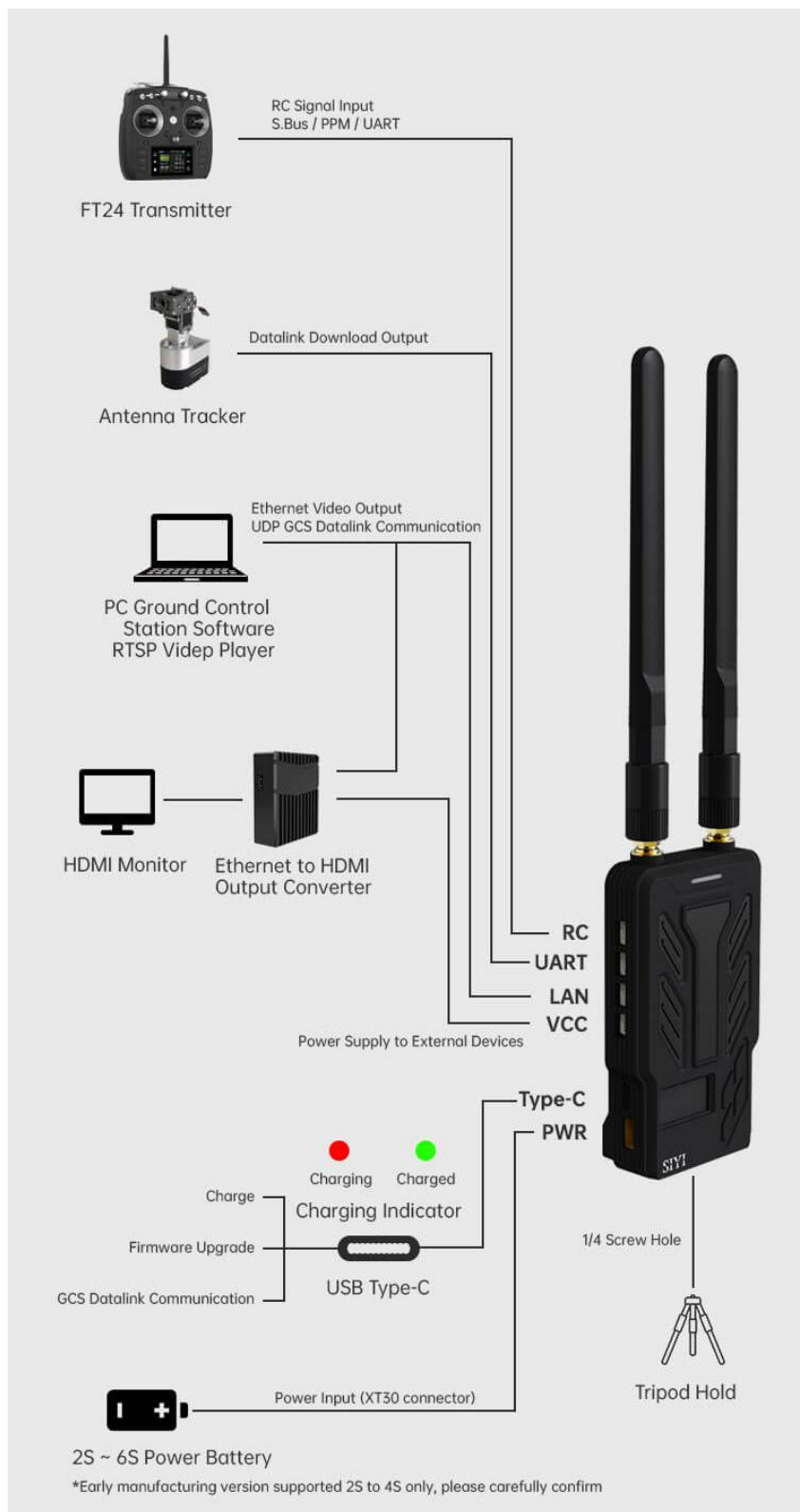

**Note:**

Please confirm the version information with official technical support before connecting the 6S power supply.

## Air Unit

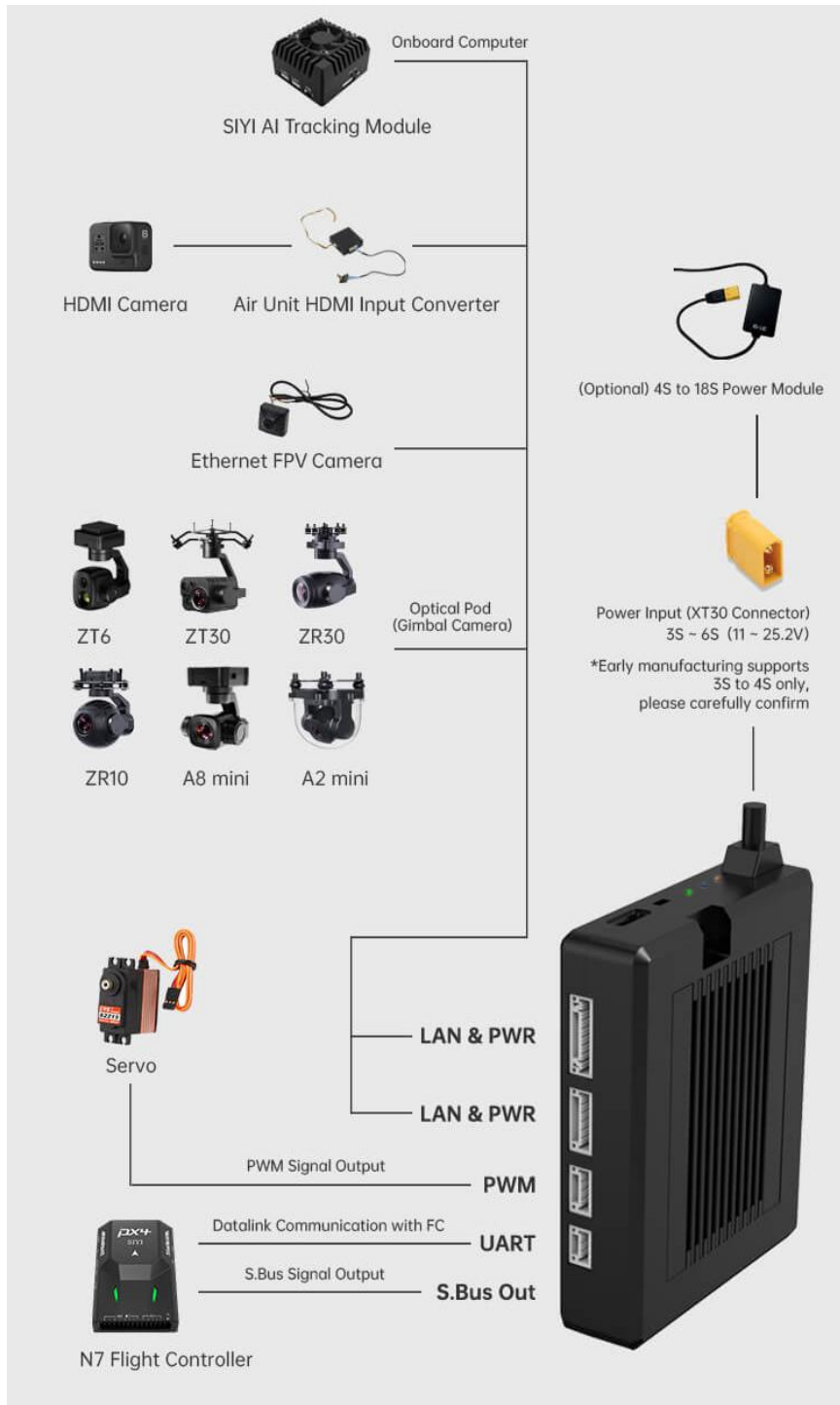

# SIYI

## 1.2.4 OLED Function Display

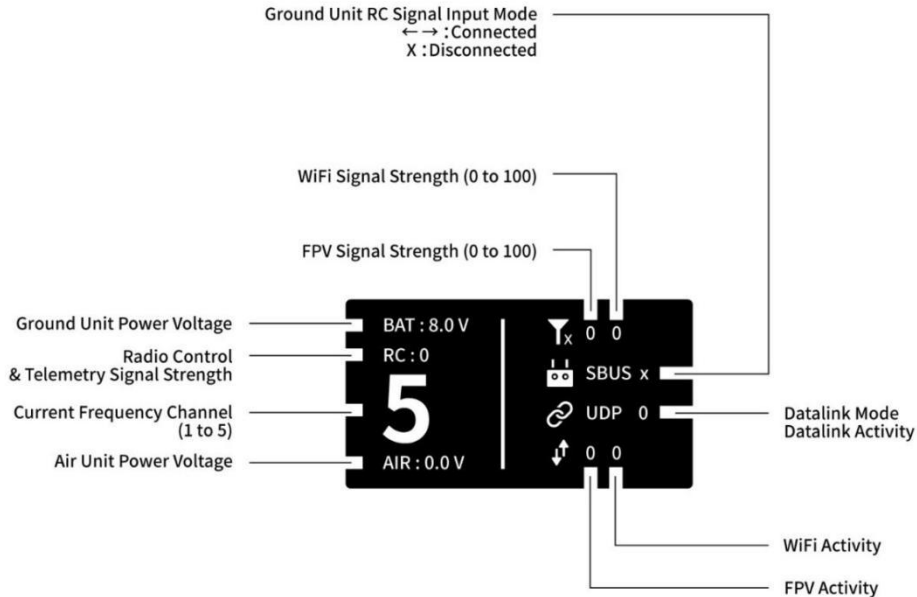

## 1.3 Technical Specification

### Overall

<b>Max Transmission Range</b>	20 km (Unobstructed, free of interference)
<b>Channels</b>	16 communication channels
<b>Datalink Compatible Flight Controllers</b>	PX4 / ArduPilot Open-source Flight Controllers: SIYI N7 Autopilot, etc.  INAV Open-source Flight Controllers
<b>Video Stream Compatible Android GCS</b>	SIYI Original App: SIYI FPV  Open-source GCS: QGroundControl Mission Planner
<b>Video Stream Compatible Windows GCS</b>	Open-source GCS: QGroundControl Mission Planner (H264 only)

## Ground Unit

<b>Monitor Display</b>	0.96-inch OLED Display
<b>Compatible Battery Type</b>	NP-F550 / F750 / F950 quick release battery (HM30 Fly More Combo comes with an NP-F750 battery)
<b>Fast Charging Protocol</b>	PD 30W
<b>Antenna Gain</b>	Standard Omni Antenna: 5 dBi Standard Long-Range Antenna: 11 dBi Lollipop Antenna: 5 dBi (optional)
<b>Interface &amp; Ports</b>	S.Bus / PPM RC Signal Input: RC (GH1.25 4-pin) Datalink Output: UART (GH1.25 4-pin) Ethernet Port: LAN (GH1.25 4-pin) Power Output: VCC (GH1.25 4-pin) Datalink Output to GCS: Type-C Firmware Upgrade: Type-C Charging to Quick Release Battery: Type-C Power Input: PWR (XT30) Tripod Connector: 1/4-inch Screw Hole
<b>Power Consumption</b>	5 W
<b>Dimensions</b>	109 x 61 x 28 mm (Antenna and battery excluded)
<b>Weight</b>	132 g (Antenna and battery excluded)
<b>Waterproof Level</b>	IP53
<b>Working Temperature</b>	-10 ~ 50°C

## Air Unit

<b>Signal Output</b>	16 channels of SBUS 5 channels of PWM
<b>Interface &amp; Ports</b>	S.Bus RC Signal Output: S.Bus Out (GH1.25 3-Pin) Datalink (to FC): UART (GH1.25 4-Pin) PWM Channel 1 to 5: PWM (GH1.25 6-Pin) Video Input / Network Communication: LAN & PWR (GH1.25 8-Pin) Firmware Upgrade: Type-C
<b>Antenna Gain</b>	Omni Antenna: 5 dBi Lollipop Antenna: 5 dBi (optional)
<b>Working Voltage</b>	HM30 Air Unit: 3S ~ 6S / 12.6 ~ 25.2 V  4S to 18S Power Module (optional): 16.8 ~ 75.6 V
<b>Power Consumption</b>	HM30 Air Unit: - Average: 2.8 W - Summit: 12 W  HM30 Air Unit + 4S to 18S Power Module: - Average: 3.2 W - Summit: 12 W
<b>Dimensions</b> (Antenna Excluded)	70 x 55 x 22.5 mm (fan included) 70 x 55 x 16 mm (fan excluded)
<b>Weight</b> (Antenna Excluded)	HM30 Air Unit: 74 g  HM30 Air Unit + 4S to 18S Power Module: 109 g
<b>Working Temperature</b>	-10 ~ 50°C

## R1M Recording FPV Camera

<b>Video Output</b>	Ethernet
<b>Image Sensor</b>	1/2.9 Inch, 2 MP
<b>FOV</b>	Diagonal: 90° Horizontal: 80°
<b>Working Voltage</b>	12 V
<b>Power Consumption</b>	2.5 W
<b>Video Recording Resolution</b>	1080p (1920*1080) @ 30 fps 720p (1280*720) @ 30 fps
<b>Video Recording Bitrate</b>	12 Mbps
<b>Video Recording Format</b>	MP4
<b>Supported TF / SD Card Type</b>	MicroSD Class10 Less than 32GB
<b>Supported File System</b>	FAT32
<b>Dimensions</b>	42 x 42 x 25 mm
<b>Weight</b>	23 g
<b>Working Temperature</b>	-10 ~ 50°C

## Air Unit HDMI Input Converter

(Optional)

<b>Video Input</b>	Micro HDMI
<b>Video Output</b>	Ethernet
<b>Working Voltage</b>	12 V
<b>Power Consumption</b>	3 W
<b>Video Recording Resolution</b>	1080p (1920*1080) @ 30 fps 720p (1280*720) @ 30 fps
<b>Video Recording Bitrate</b>	12 Mbps (H265 codec)
<b>Supported File System</b>	FAT32

<b>Video Recording Format</b>	H265
<b>Supported TF / SD Card Type</b>	MicroSD Class10 Less than 32GB
<b>Dimensions</b>	42 x 41 x 11 mm
<b>Weight</b>	26 g
<b>Working Temperature</b>	-10 ~ 50°C

## Ethernet to HDMI Converter

(Optional)

<b>Video Input Port</b>	Ethernet
<b>Video Output Port</b>	Micro-HDMI
<b>Working Voltage</b>	8.4 ~ 25.2 V
<b>Power Consumption</b>	Average: 1.5 W Summit: 5 W
<b>Video Recording Resolution</b>	1080p (1920*1080) @ 30 fps 720p (1280*720) @ 30 fps
<b>Video Recording Bitrate</b>	12 Mbps (H265 codec)
<b>Supported File System</b>	FAT32 ExFAT
<b>Video Recording Format</b>	MP4
<b>Supported TF / SD Card Type</b>	MicroSD Class10, max 128 GB
<b>Dimensions</b>	42 x 37 x 13 mm
<b>Weight</b>	25 g
<b>Working Temperature</b>	-10 ~ 55°C

# SIYI

## 1.4 Packing List

### Normal Edition

Standard Combo	Fly More Combo
1 x HM30 Ground Unit 2 x Standard Omni Antenna 2 x Long Range Antenna	
1 x HM30 Air Unit 2 x Standard Omni Antenna	
1 x R1M Recording FPV Camera	
1 x Ground Unit XT30 Male Power Cable 1 x Type-C to Type-C Charging Cable 1 x Type-C to USB-A Converter 1 x Type-C to Micro-USB Cable 1 x GH1.25 4Pin to S.Bus Connector Cable 1 x GH1.25 4Pin to RJ45 Connector Cable	
1 x PX4 / ArduPilot Flight Controller Telemetry Cable 1 x Air Unit S.Bus Cable 1 x PWM Cable 1 x Ethernet Cable	
	1 x NP-F750 2S Chargeable Battery 1 x 20W PD Charger (Type-C, US Plug)

## 1.5 Indicator Definition

The status indicators on ground unit and air unit use different colors and different blinking frequencies to indicate the system's working or abnormal status.

# SIYI

## 1.5.1 Ground Unit Indicator

- Solid Red: No communication between ground unit and air unit.
  - Fast Red Blinks: Ground unit is binding to air unit.
  - Slow Red Blinks: Ground unit firmware does not match to air unit firmware.
  - ● ● Triple Red Blinks: System initialization failed.
  - ● Fast Red-Yellow Blinks: FPV firmware does not match to function firmware.
  - ● ● Slow Red-Blue-Yellow Blinks: System is starting.
  - ● ● Fast Red-Blue-Yellow Blinks: Firmware is updating.
  - ● Fast Yellow Blinks: Ground unit voltage abnormal.
  - ● Double Yellow Blinks: Ground unit Bluetooth is not identified.
  - ● ● Triple Yellow Blinks: Transmission system data overload alert, level one.
  - ● ● ● Slow Yellow Blinks: Transmission system data overload alert, level two.
  - ● Yellow-Red Blinks: Ground unit overheat alert, level one.
  - ● ● Yellow-Red-Red Blinks: Ground unit overheat alert, level two.
  - ● ● ● Yellow-Red Blinks: Ground unit overheat alert, level three.
  - Solid Blue: Perfect communication, receiving 100% data package.
- Blue Blinks: Blinking frequency indicates the system's signal quality. More frequently it blinks, worse the signal quality is.

# SIYI

- Slow Blue Blinks (1 Hz): Receiving 95% to 99% data package.
- Blue Blinks (every 3/5 second): Receiving 50% to 75% data package.
- Blue Blinks (every 3/10 second): Receiving 25% to 50% data package.
- Blue Blinks (every 1/25 second): Receiving less than 25% data package.
- ● Double Blue Blinks: Failsafe set successfully.
- ● Blue-Red Blinks: Air unit overheat alert, level one.
- ● ● Blue-Red Blinks: Air unit overheat alert, level two.
- ● ● ● Blue-Red Blinks: Air unit overheat alert, level three.

## 1.5.2 Air Unit Indicator

- Solid Red: No communication between ground unit and air unit.
- Fast Red Blinks: Air unit is binding to ground unit.
- Slow Red Blinks: Air unit firmware does not match to ground unit firmware.
- ● ● Triple Red Blinks: System initialization failed.
- ● ● Slow Red-Green-Yellow Blinks: System is starting.
- ● ● Fast Red-Green-Yellow Blinks: Firmware is updating.
- Yellow Blinks: Air unit low voltage alert (voltage input lower than 12V).
- Solid Green: Perfect communication, 100% data package received.

# SIYI

Green Blinks: Blinking speed indicates the system's signal strength. More frequently it blinks, worse the signal quality is.

- Slow Green Blinks (1 Hz): 95% to 99% data package received.
- Green Blinks (every 3/5 second): 50% to 75% data package received.
- Green Blinks (every 3/10 second): 25% to 50% data package received.
- Green Blinks (every 1/25 second): less than 25% data package received.
- ● Fast Green-Red Blinks: Air unit starts to bind wirelessly (plug power three times to trigger).
- ● Green-Red Blinks: Air unit overheat alert, level one.
- ● ● Green-Red-Red Blinks: Air unit overheat alert, level two.
- ● ● ● Green-Red-Red-Red Blinks: Air unit overheat alert, level three.

# SIYI

## CHAPTER 2 GET READY TO USE

### 2.1 Ground Unit

#### 2.1.1 Power On / Off

Power On:

When the ground unit is off power, press the power button once, the OLED screen will display “Press again to power on”. Then immediately press and hold the power button for about two seconds and the ground unit is powered on.

Power Off:

When the ground unit is working, press the power button once, the OLED screen will display “press again to power off”. Then immediately press and hold the power button for about two seconds, the ground unit will be turned off.

#### 2.1.2 Charging

When HM30 ground unit is mounted with the external NP-F550 / 750 / 950 series chargeable battery and the ground unit is power off, the battery can be charged through the Type-C port using the SIYI original PD fast charger.

# SIYI

## Steps

1. Connect the ground unit to the PD charger and plug it into power supply.
2. The charging indicator lights on red; ground unit starts charging.
3. The charging indicator lights on green, charging is finished.



## CAUTION

Normal 5V charger adapter cannot charge the ground unit, please do use SIYI original PD fast charger.

The ground unit cannot be charged when it is working. Please do power off the ground unit before charging.

### 2.1.3 Charging Indicator

- Solid Red: In charging.
- Solid Green: Charging finished.

# SIYI

## **2.2 Important Instructions on Promotion to HM30 Communication Range and Video Fluency**

To have the best communication range and video fluency with HM30 system, please carefully read the below tips for antenna options, antenna setup, and link configuration.

### **2.2.1 General Precautions**

1. It is suggested that not to run SIYI FPV app and QGroundControl app simultaneously with video streaming, not even running one at backstage, as it still occupies bandwidth thereby lower the communication range.
2. Only power batteries are allowed to power the ground unit and the air unit. HD image transmission system requires very high standard to the current of power supply, the instancy of the current response, and the current ripple. Power supply from a third-party power module, modified power module or from PDB may interfere the link stability and the communication range. If you do need the power module, it is suggested to use the SIYI original 4S to 18S power module.
3. It is first recommended to establish a wired connection with the target device through the HM30 ground-side network port to ensure link

# SIYI

stability and video fluency. If the target device is far away from the HM30 ground terminal, it is recommended to use a non-5 GHz frequency band high-power external WiFi module.

4. When the battery level of the mobile device communicating with the HM30 ground unit is too low or it is too hot, the decoding performance may decrease, resulting in unsmooth video, high latency, etc. Please pay special attention to this.

## **2.2.2 General Antenna Options and Wireless Mode Configuration for Different Range**

### **1. 0 to 8 Kilometers Range**

Two standard omni antennas on the ground unit.

Wireless mode: 5 km or 8 km low latency.

### **2. 8 to 15 Kilometers Range**

Two standard omni antennas or two standard long-range antennas on ground unit.

Wireless mode: 15 km GCS.

# SIYI

## 3. 15 to 24 Kilometers GCS Flight

Two standard long-range antennas or higher gain patch antennas on ground unit.

Wireless mode: 24 km GCS.

Mission control suggested in GCS!

## 4. 24 to 40 Kilometers GCS Flight

**THIS MODE IS FOR PROFESSIONAL PILOTS ONLY!!!**

We do not encourage everyone to try this mode. Improper use may cause lagging or even loss of control!

Two 17 dB patch antennas or higher gain patch antennas on ground unit.

Wireless mode: 40 km GCS.

Mission control in GCS only!

5. The signal at the top of the standard omnidirectional antenna is weak.

When flying directly above the ground, the flying height of the aircraft should be as low as 100 meters.

6. When the ground unit is working with the standard long-range antennas or patch antennas, the aircraft should always be in front of

# SIYI

the antenna panel instead of being vertical of the antenna or on opposite.

7. Only the standard omni antennas are suggested for the air unit. If your aircraft is too small to mount the omni antennas, or you worry about the weak signal of the top part, then you can consider using SIYI lollipop antennas. Lollipop antennas performs shorter range than the standard omni antennas.

## 2.2.3 How to Place the Standard Omni Antennas on Ground Unit

1. The SMA connectors should be screwed tightly.
2. The antennas should stand vertically from the control panel of the ground unit, and the antennas' flat side should always point to the aircraft or the vehicle. Do not cross or overlap the antennas during mission.



# SIYI

## **2.2.4 How to Place the Long-Range Patch Antennas on Ground Unit**

1. The SMA connectors should be screwed tightly.
2. Long-range patch antennas are directional, which should always be pointing to the aircraft during flight.
3. When you are using SIYI standard long-range antennas, please make its short side be parallel with horizon and its long side be vertical of the control panel to get the best signal quality.

## **2.2.5 How to Place Air Unit Antennas**

1. The SMA connectors should be screwed tightly.
2. On multirotor, the standard omni antennas should be hanging vertically from the drone arms with the antenna heads pointing to ground, and the antenna flat side should always point to the ground unit during flight. On plane, the standard omni antenna can stand vertically above the wings, and the antenna flat side should always point to the ground unit during flight.
3. The air unit antenna feeder wire should be placed away from E.S.C and motors, and any other equipment with heavy current or interference. Do not cross or overlap the antenna feeder wires.
4. The antenna body, feeder wire, and the SMA connectors should not touch the metal / carbon-fiber structure parts directly. Please reserve

# SIYI

- at least 10 mm distance between these parts and the structure parts.
5. The two air unit antennas should be placed away from each other for at least 50 mm distance. And try your best to avoid any kinds of obstruction between the ground unit and the aircraft during flight.
  6. Please be very careful with the antenna wire's SMA connectors and its solder connectors. Do not drag them or bend them in case of any damage. To adjust the position of the antenna, please always try to bend the middle part of the antenna feeder wires.



## CAUTION

As shown in the picture below, for small and medium-sized multi-rotor drones, the air unit antenna should be placed downward perpendicular to the arm to keep the flat surface of the antenna facing the direction of the remote controller.



As shown in the figure below, for large multi-rotor drones, the air unit antenna should be placed vertically downwards from the motor base to keep the flat surface of the antenna facing the direction of the remote control.

# SIYI



As shown in the figure below, for fixed-wing aircraft, the air unit antenna can be placed vertically to the wings or vertical tail upwards and try to keep the flat surface of the antenna facing the direction of the remote controller.

SIYI

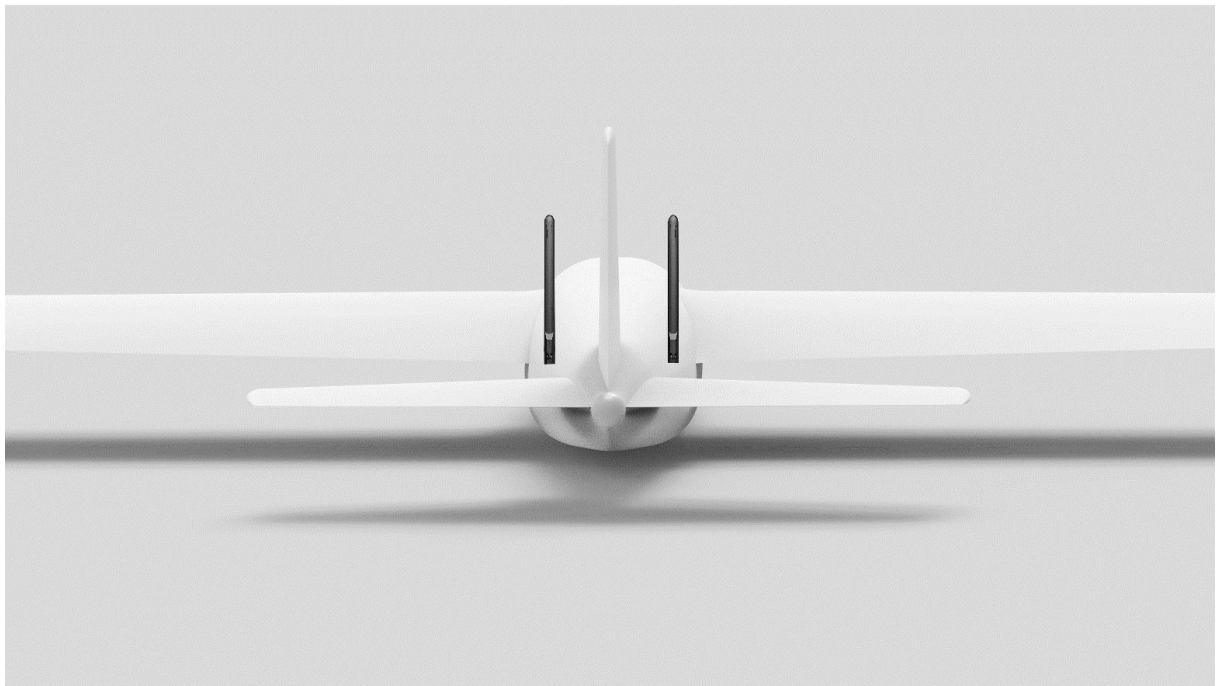
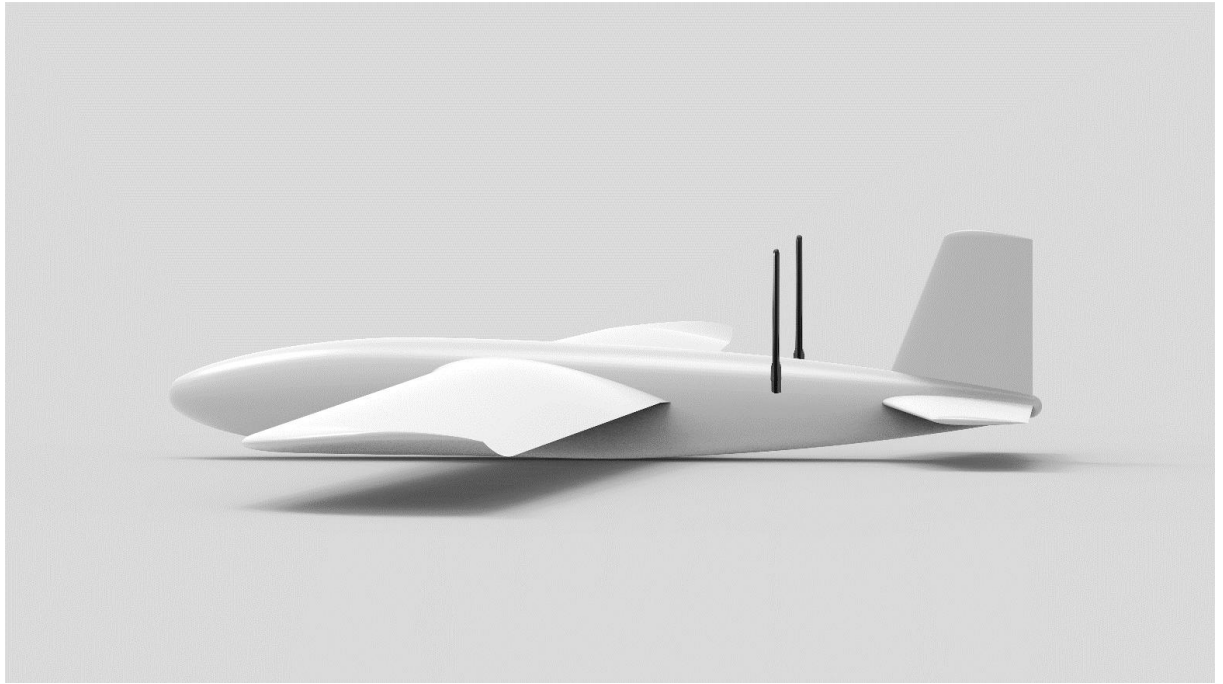

# SIYI

## 2.2.6 The Communication Range Is Not as Expected and You Need Factory Support, Here Are the Necessary Information We Need

1. The obvious things that make you think about range is not good.
  - Signal Loss: Image disappears, and ground unit status indicator is red.
  - Only image disappears (ground unit status indicator is green).
2. Flight altitude and distance of your drone when you observe the above things.
3. Flight test environment (pictures or videos taken in the orientation of the flight).
4. Check software information relevant to communication.
  - Wireless Mode
  - Ground and Air Unit Firmware Version
  - SIYI FPV app version

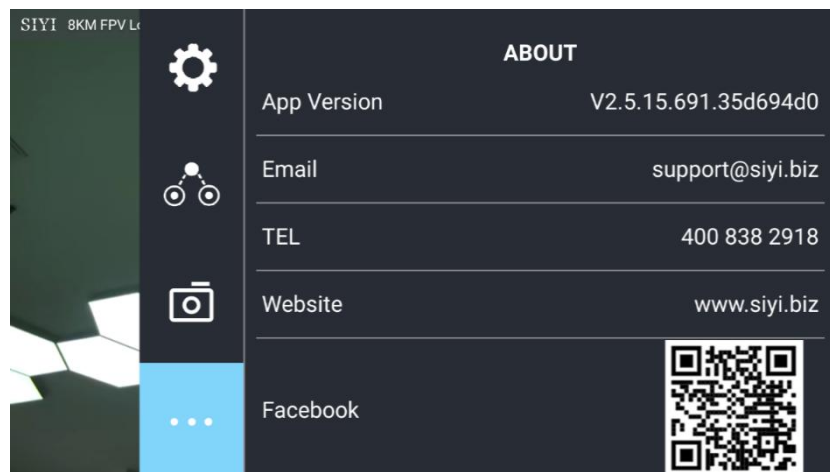

# SIYI

5. Check hardware configuration relevant to communication.
  - Ground Unit Antenna Type, Antenna Installation, Operating Angle  
(all with pictures)
  - Air Unit Antenna Type, Antenna Installation (both with pictures)
  - Air Unit Power Supply / Voltage and if the original BEC is removed / modified.
6. If all above trouble shooting still didn't help find the cause to unexpected range, please provide a screenshot of SIYI FPV app with all OSD turned on when the drone is flying closely to the range limit that you have experienced, or provide a screen recorded video of the running SIYI FPV app during the whole flight.

## CHAPTER 3 MENU SETTINGS

Users can configure HM30 ground unit in the built-in OLED screen.

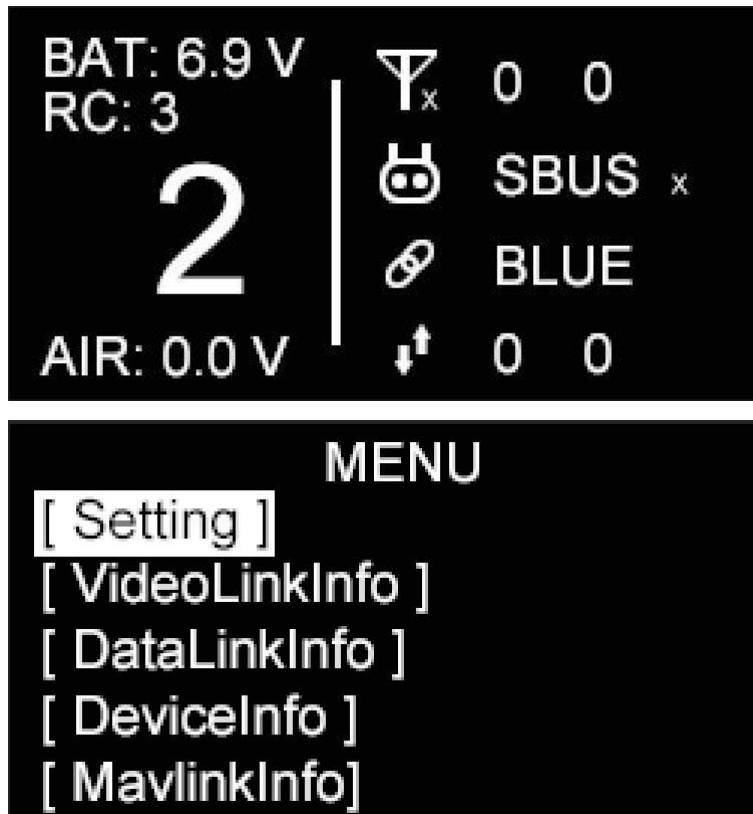

### Mark

This chapter was edited according to HM30 ground unit firmware version 0.2.3.

# SIYI

## 3.1 GENERAL

Basic functions of the HM30 system.



### About Settings

Rec. No (Air Unit No.): Display the number of the currently bound air unit.

Bind: Start to bind the ground unit to an air unit.

RC Mode (RC): Display the current radio control signal input mode of the ground unit's RC port.

Datalink Mode (Datalink): Display the current datalink communication port of the HM30 system.

BAUD: The baud rate for the HM30 link.

# SIYI

AAT. BAUD: The baud rate for the communication between HM30 ground unit datalink port and the antenna tracker.

FailsafeSet (Failsafe): Set failsafe function in the HM30 system together with the radio controller.

RSSI CH: Assign an RC channel for RSSI data.

Wireless Mode (Wireless): Set a wireless mode for the HM30 system.

Video Mode (Video Out): Assign a video output port for HM30 ground unit.

## 3.1.1 Air Unit Number

Air unit number means that users can save multiple sets of air unit binding information and corresponding channel setting data in the same ground unit. In this way, after each air unit is bound to the ground unit for the first time, users no longer need to re-bind to switch among them.

### **DANGER**

Do not attempt this function during flight, otherwise the link will lose control.

# SIYI

## 3.1.2 Bind



Please follow the steps below to bind HM30 ground unit and HM30 air unit.

1. Press the “Up” button and the “Down” button to move the cursor to the “Bind” button and press the “Select” button.
2. Ground unit status indicator starts to blink red fast. “bind” turns to “binding”.
3. Then press and hold the binding button on the air unit for about two seconds. Air unit status indicator starts to blink red fast as well.
4. Let’s wait for five to ten seconds till both status indicators on the ground unit and the air unit turn to solid blue. Binding is finished.

### **DANGER**

Do not attempt this function during flight, otherwise the link will lose control.

# SIYI

## 3.1.3 RC Signal Input

The RC port on HM30 ground unit supports three RC signal input modes.

S.Bus, PPM, and UART.



### Steps

1. Press the “Up” button and the “Down” button to move the cursor to the current RC signal input port and press the “Select” button.
2. The OLED screen will alert “Do not configure (this function) in flight in case of losing control!”



3. Press the “Select” button again to go into the page of “RC Signal Input”.
4. Move the cursor to the RC signal input mode needed.

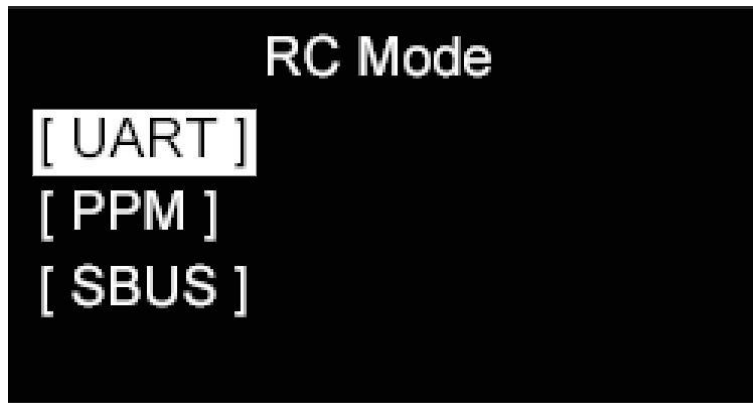

5. Return to the initial page, if there is an “x” icon right after the selected RC input mode, there is no RC signal input through the RC port. If the icon is “←→”, there is RC signal input.

 **DANGER**

Do not attempt this function during flight, otherwise the link will lose control.

# SIYI

## 3.1.4 Datalink Mode

HM30 ground unit supports multiple ways to establish datalink connection to the GCS. They are Bluetooth, Type-C, UART, and UDP (through LAN / WiFi).



### About Datalink Mode

Bluetooth: Establish datalink connection with the GCS through HM30 ground unit's internal Bluetooth module.

Type-C: Establish datalink connection with the GCS through HM30 ground unit's Type-C port.

UART: Establish datalink connection with the GCS through HM30 ground unit's UART port.

UDP: Establish datalink connection with the GCS through HM30 ground unit's LAN port or the internal WiFi module in UDP protocol.

### Mark

Due to a supply chain issue, HM30 ground unit's internal WiFi module

# SIYI

may be discontinued in the future.

## Steps

1. Press the “Up” button and the “Down” button to move the cursor to the current datalink mode and press the “Select” button.
2. The OLED screen will alert “Do not configure (this function) in flight in case of losing control!”



3. Press the “Select” button again to go into the page of “Datalink Mode”.
4. Move the cursor to the datalink mode needed and select.

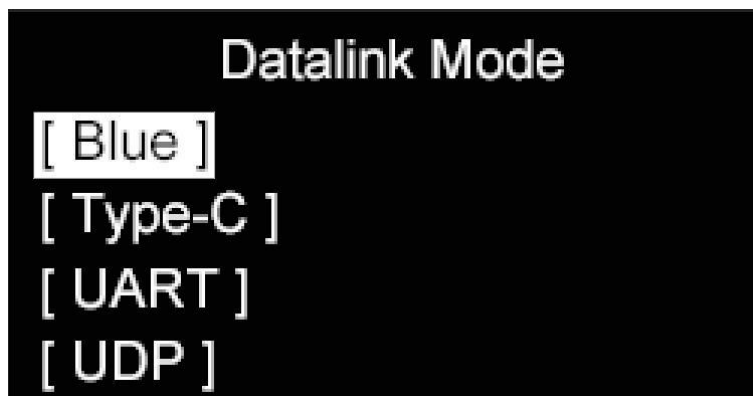

# SIYI

## Mark

When the datalink mode is Bluetooth, UDP, or Type-C, there is only datalink download through the HM30 ground unit's UART port which can be used for antenna tracker.

## DANGER

Do not attempt this function during flight, otherwise the link will lose control.

### 3.1.5 Datalink Baud Rate

HM30 system can establish datalink connection between the flight controller and the GCS in different baud rates. The available baud rates are 9600, 38400, 57600, 115200, and 230400.

```
SETTING 1 / 2
Rec. No: 00 Bind
RC Mode: UART x
Datalink Mode: Blue
BAUD: 115200
AAT. BAUD: 115200
```

### Steps

1. Press the “Up” button and the “Down” button to move the cursor to

# SIYI

the current datalink baud rate and press the “Select” button.

2. The OLED screen will alert “Configure (this function) in communication with the air unit!”



3. Press the “Select” button again to go into the page of “Datalink Baud Rate”.
4. Move the cursor to the datalink baud rate needed and select.

## **DANGER**

Do not attempt this function during flight, otherwise the link will lose control.

# SIYI

## 3.1.6 AAT (Antenna Tracker) Baud Rate

HM30 ground unit can output data to an antenna tracker in two different baud rates, which are 57600 and 115200.



### Steps

1. Press the “Up” button and the “Down” button to move the cursor to the current AAT baud rate and press the “Select” button.
2. Each time the button is pressed, antenna tracker baud rate will be switched between 57600 and 115200.

### Mark

When datalink mode is under UART, AAT baud rate configuration will not take effect.

# SIYI

## 3.1.7 Failsafe

HM30 ground unit supports configuring failsafe function together with a radio controller when there is RC signal input.



### CAUTION

Please be sure to set up the fail-safe function in either the radio controller & the ground unit or in the flight controller & GCS after the ground unit and the air unit are bound for the first time!

Failsafe function means that when the communication between the ground unit and the air end is lost, the air unit continues to output the preset channel value to avoid a crash to the greatest extent.

### Steps

1. Press the “Up” button and the “Down” button to move the cursor to the second page of “General” and to “Set” after “Failsafe”. Press the “Select” button.

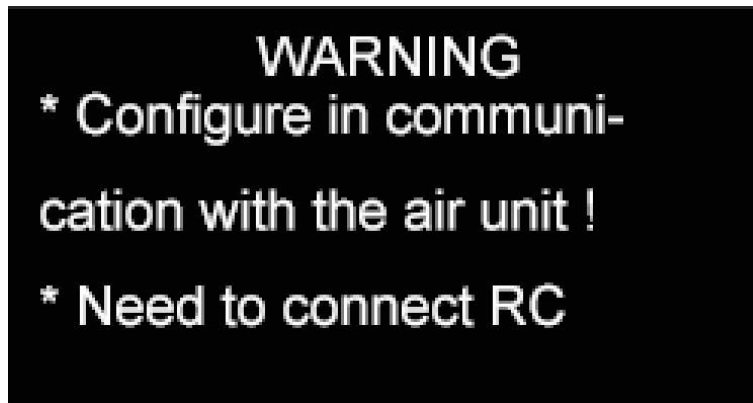

2. The OLED screen will alert “Configure (this function) in communication with the air unit!” and “Need to connect (HM30 ground unit) with the radio controller!”.
3. Press the “Select” button again, HM30 ground unit will read the RC signal input value and set it as the failsafe channel value.

## **DANGER**

Do not attempt this function during flight, otherwise the link will lose control.

## **Mark**

If the ground unit was not in communication with the air unit, failsafe configuration does not take effect.

If there was no RC signal input to the ground unit, failsafe configuration does not take effect.

# SIYI

## 3.1.8 RSSI Channel

HM30 ground unit supports assigning a communication channel for RSSI data.



### Steps

- 1.The “OFF” value after “RSSI CH” indicates that no communication channel is assigned for RSSI. If the value is a number, it indicates the current RSSI channel.
- 2.Press the “Up” button and the “Down” button to move the cursor to the current RSSI channel value and press the “Select” button to switch channels (from the 5th communication channel to the 16th which HM30 system supports).

# SIYI

## 3.1.9 Wireless Mode

HM30 system can be compatible with different antennas in types and gains to have the best communication performance and the longest range by switching wireless modes.

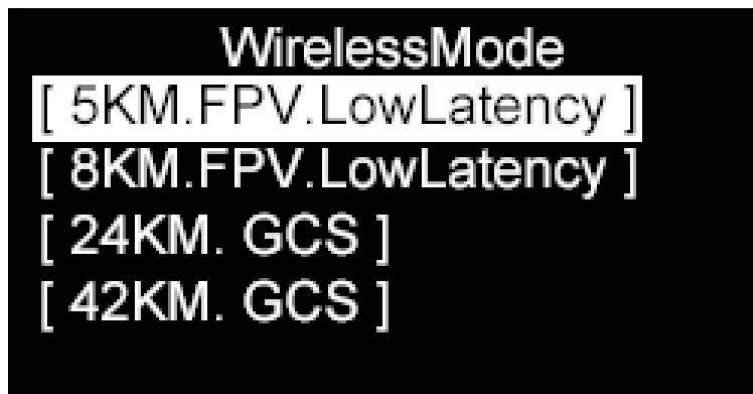

### Regarding Wireless Modes:

5KM.FPV.LowLatency: 5 kilometers low-latency FPV flight mode

8KM.FPV.LowLatency: 8 kilometers low-latency FPV flight mode

15KM.GCS: 15 kilometers Ground Control Station long-range mode

24KM.GCS: 24 kilometers Ground Control Station long-range mode

# SIYI

## Steps

1. Press the “Up” button and the “Down” button to move the cursor to the second page of the “General” menu and to the current “Wireless Mode”. Press the “Select” button.
2. The OLED screen will alert “Do not configure (this function) in flight in case of losing control!” and “Configure (this function) in communication with the air unit!”.



3. Press the “Select” button again to go into the page of “Wireless Mode”.
4. Move the cursor to the wireless mode needed and select.

## **DANGER**

Do not attempt this function during flight, otherwise the link will lose control.

## **Mark**

Before configuring wireless modes, please carefully read the chapter 2.2 in this manual “Important Instructions on Promotion to Communication

# SIYI

Range and Video Fluency”.

## 3.2 Video Output

HM30 ground unit supports multiple ways to output video stream. They are the internal WiFi module, USB WiFi through Type-C Port, and LAN port.



### About Video Output Mode

WiFi: Output video stream through HM30 ground unit's internal WiFi module.

Type-C WiFi: Output video through an external USB WiFi module connected to the Type-C port on HM30 ground unit.

### Mark

Due to a supply chain issue, HM30 ground unit's internal WiFi module may be discontinued in the future.

# SIYI

## Steps

1. Press the “Up” button and the “Down” button to move the cursor to the current video output port and press the “Select” button.
2. The OLED screen will alert “Do not configure (this function) in flight in case of losing control!”



3. Press the “Select” button to go into the page of “Video Output”.
4. Move the cursor to the video output mode needed and select.

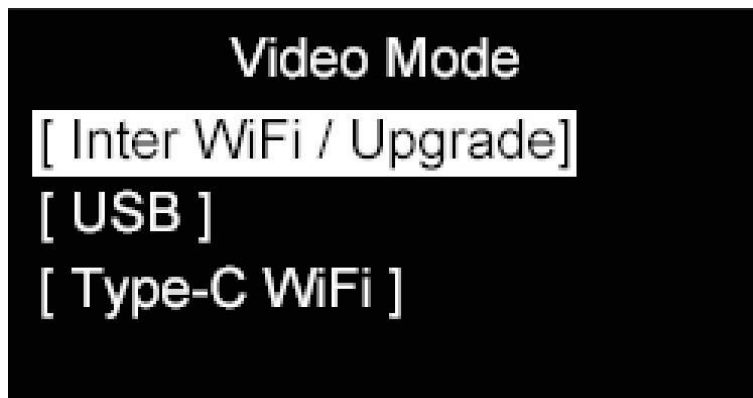

## Mark

For more detail on video output, please refer to the Chapter 6 “Image Transmission”.

# SIYI

## 3.3 VIDEO

Real-time working status of the HM30 image transmission link.

```
          VIDEO INFO   1 / 2
CH: 104      Signal: 0
RSSI: 0      Ntime: 0
UpB: 0.0     DownB: 0.0
UPData:      0.0 KB
DownData:    0.0 KB
```

### About VIDEO

CH: The communication frequency channel under the current working frequency of the image transmission link.

Signal: Signal strength of the image transmission link (in percentage, from 0 to 100).

RSSI: Signal strength of the image transmission link (in dBm).

Ntime: Communication latency of the image transmission link. Latency time will accumulate after losing control.

Up B: Uploading bandwidth of the image transmission link.

Down B: Downloading bandwidth of the image transmission link.

Up Data: Uploading data amount of the image transmission link.

Down Data: Downloading data amount of the image transmission link.

# SIYI

## 3.4 DATALINK

Real-time working status of the HM30 datalink.



DATALINK INFO	
Freq:	3
ValidPack:	3
PackRate:	3
DataUp:	0
DataDown:	0

### About DATALINK

Frequency: The current working frequency of datalink.

Valid Pack: Valid package amount of datalink.

Valid Pack Rate: Valid package rate (in percentage) of datalink.

Data Up: Uploading data amount of datalink.

Data Down: Downloading data amount of datalink.

# SIYI

## 3.5 Device Information

Major hardware and software information of the HM30 system.

```
DEVICE INFO    1 / 2
HardID: 6A02259766
FirmwareVer: 0.1.7
SkyFirmwareVer: 0.0.0
VideoVer: 0.2.2
SkyVideoVer: 0.0.0

DEVICE INFO    2 / 2
LoaderVer: 0.1.0
```

### About Device Information

ID: Unique device ID of the HM30 system.

Ground Unit Firmware: Firmware version of HM30 ground unit.

Air Unit Firmware: Firmware version of HM30 air unit.

Ground Unit FPV Firmware: FPV firmware version of HM30 ground unit.

Air Unit FPV Firmware: FPV firmware version of HM30 air unit.

Boot Loader.: Boot loader version of HM30 ground unit.

# SIYI

## 3.6 Mavlink Information

The Mavlink information is for reference only.

## 3.7 Multiple Links

The detailed operation mode of the "dual operator" function can be set under this feature menu.

### About Multiple Links

**Function Type:** Switch the function type to "Dual Operator" and set the current ground unit as either "Master" or "Slave."

**Binding:** After configuring the function type, bind the Master and Slave alternately to the same air unit.

**Control Switch:** Define a button or switch to toggle control between the Master and Slave for specific channels in "Dual Operator" mode.

**Control Channel:** In "Dual Operator" mode, define the channel mapping for the Master and assign control of designated channels to the Slave.

### Dual Control with a Single Aircraft

The "Dual-Control" feature is designed for scenarios involving two

# SIYI

operators. It supports up to two ground control units linking to a single air unit simultaneously. One unit can be used to control the drone's flight attitude, while the other handles payloads such as gimbal cameras or electro-optical pods. In dual-control mode, both ground units can display the same video feed from one camera source, or each can display feeds from different camera sources independently.

## ● Usage Steps

1. Prepare two ground control units with the dual-control version and enter the "MENU" menu.

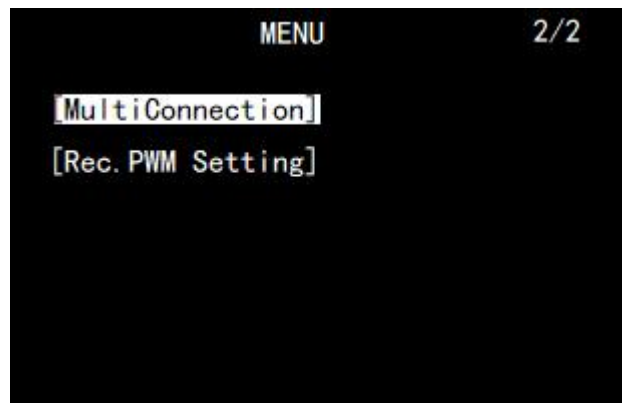

2. Locate and enter the "MultiConnection" option.
3. Change the "TYPE" setting to "ON" mode.



4. Pair the master and slave units with the air unit one after the other.
5. Dual-control setup is now complete.

## **Mark**

The “Dual Operator” function works similarly to “Wireless Coach (Master to Slave)” function. Thus, the dual and repeater edition can also be used for drone training and education.

## **DANGER**

When the “Dual Operator” function is enabled and “TX-A” lost control to the air unit, “TX-B” loses control to the air unit as well.

## **3.8 Air Unit PWM Channels**

Assign communication channels for the five pins in air unit's PWM port and for the two pins in Ethernet port.

# SIYI

## CHAPTER 4 DATALINK

Datalink is one of the core features in most SIYI links.

HM30 system supports communication with different ground control software through various hardware interface.

### 4.1 Communication with GCS via Bluetooth

#### 4.1.1 QGroundControl

1. On HM30 ground unit, go to “Settings” and set “Bluetooth” for “Datalink Mode”, and configure the correct baud rate.
2. On your mobile device or your laptop, turn on Bluetooth and search the Bluetooth device starting with the ID “SIYI-6A\*\*\*\*\*”), and pair. The PIN code is “1234”.
3. Open QGC, go to “Application Settings - Comm Links” and “Add” a new connection.

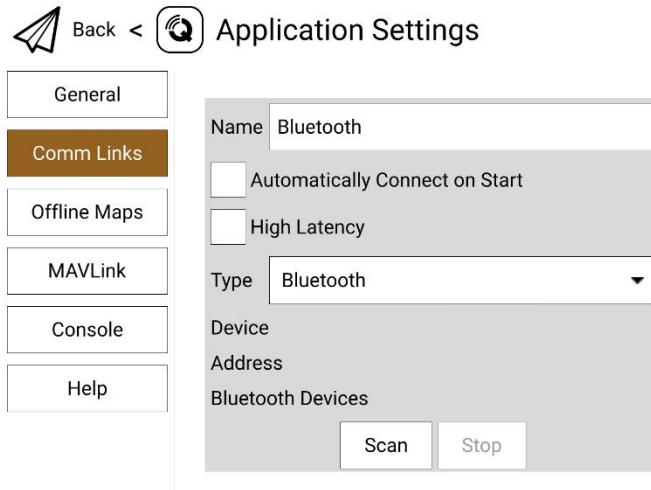

4. Set the “Type” as “Bluetooth”, then touch “Scan”.

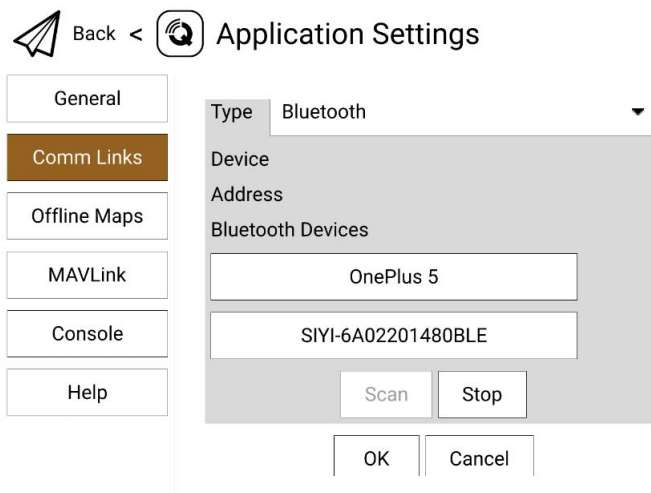

5. Select the Bluetooth device starting with the ID “SIYI-6A\*\*\*\*\*”, then “OK” to go back to the “Comm Links” page.

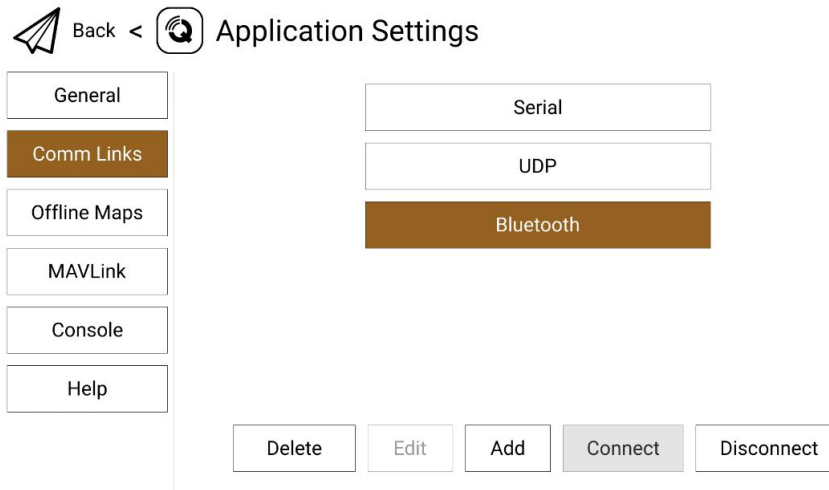

6. Confirm and start to “Connect”. The top progress bar in QGC starts to move, which means the remote controller is communicate with QGC automatically. Please wait until the datalink connection is established.

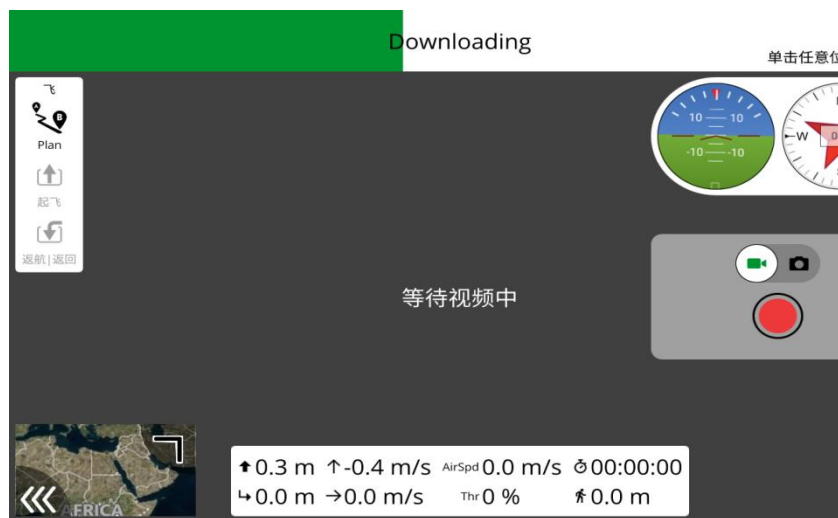

## Mark

If it is your first time to add a new connection in QGC “Comm Links”, please do not check the option “Automatically Connect on Start”. It can be checked later when you confirm that the datalink is connected successfully.

# SIYI

## 4.1.2 Mission Planner

1. On HM30 ground unit, go to “Settings” and set “Bluetooth” for “Datalink Mode”, and configure the correct baud rate.
2. On your mobile device or your laptop, turn on Bluetooth and search the Bluetooth device starting with the ID “SIYI-6A\*\*\*\*\*”), and pair. The PIN code is “1234”.
3. Run Mission Planner, select the relevant port (COM-xx Bluetooth) and match the baud rate.



4. Please wait until the datalink connection is established.



# SIYI

## 4.2 Communication with GCS under UDP Protocol through the Ground Unit LAN Port

### 4.2.1 QGroundControl

1. On HM30 ground unit, go to “Settings” and set “UDP” for “Datalink Mode”, and configure the correct baud rate.
2. Make the LAN connection between HM30 ground unit and the Windows device by using the original RJ45 cable.
3. Modify the Windows device’s Ethernet settings and make sure no IP addresses is conflict with the SIYI link.

For Example: IP Addresses = 192.168.144.30



4. Run QGroundControl, go to “Application Settings - Comm Links” page, and “Add” a new connection. Name it as “UDP”.

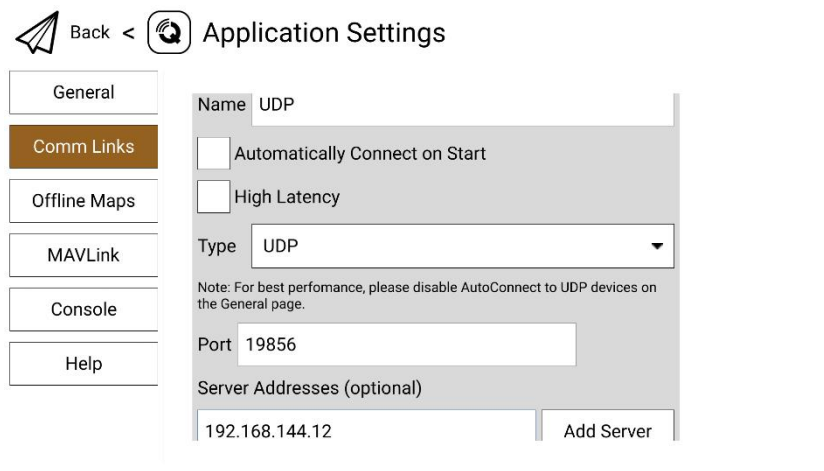

5. Set the connection “Type” as “UDP”, “Port” as “19856”, “Server Addresses” as “192.168.144.12” and “Add Server”.

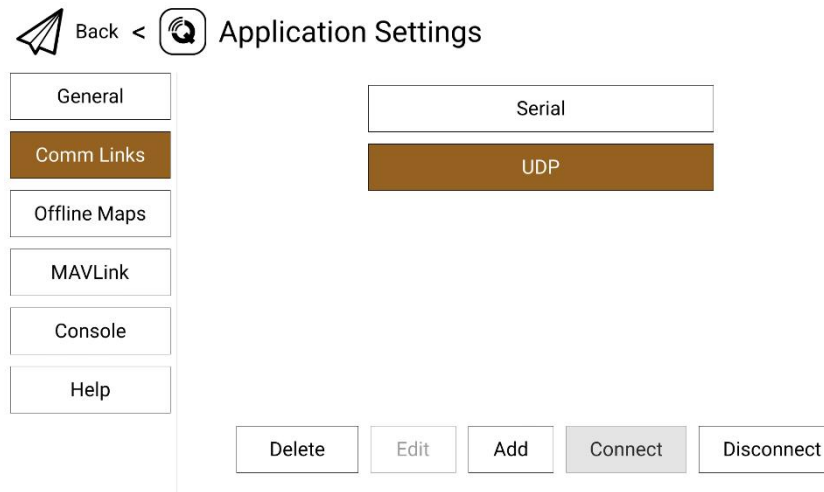

6. Confirm and start to “Connect”. The top progress bar in QGC starts to move, which means the remote controller is communicate with QGC automatically. Please wait until the datalink connection is established.

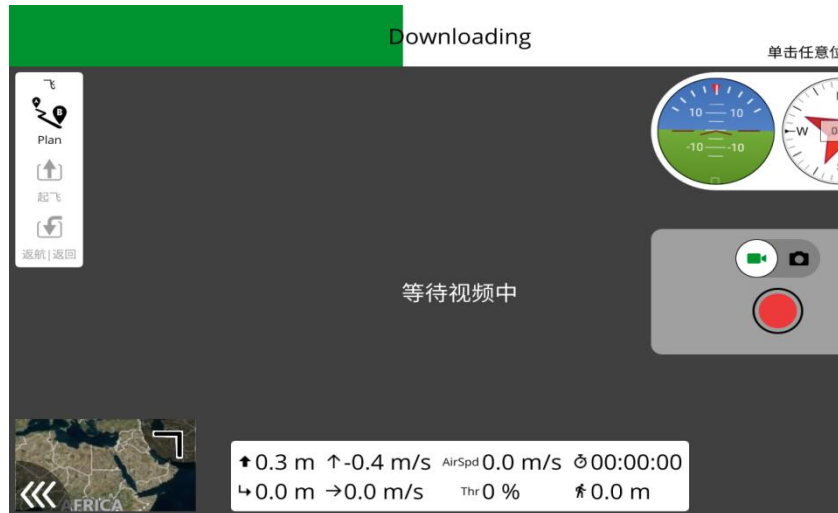

## Mark

If it is your first time to add a new connection in QGC, please do not check the option “Automatically Connect on Start”. It can be checked later when you confirm that the datalink is established successfully.

### 4.2.2 Mission Planner

1. On HM30 ground unit, go to “Settings” and set “UDP” for “Datalink Mode”, and configure the correct baud rate.
2. Make the LAN connection between HM30 ground unit and the Windows device by using the original RJ45 cable.
3. Run Mission Planner, select the relevant port (UDPCI) and match the baud rate. “Port” as “19856”. “Server addresses” as “192.168.144.12”. Then connect.



4. Please wait until the datalink connection is established.



## Mark

To use UDP datalink connection in Mission Planner, the ground unit FPV firmware should be v0.2.6 and above.

# SIYI

## 4.3 Output Datalink to Antenna Tracker through UART

HM30 ground unit can connect to an antenna tracker directly through UART.

### Steps

1. On HM30 ground unit, go to “Settings” and set “UART” for “Datalink Mode”, and configure the correct baud rate. Changing the baud rate will change the UART port’s baud rate as well.
2. Please refer to the pin map of HM30 ground unit. Wire the “TX” pin from the UART port to the “RX” pin from the antenna tracker and wire the “RX” pin from the UART port to the “TX” pin from the antenna tracker. “GND” pin to “GND” pin.
3. The UART datalink connection is established.

### Mark

Antenna trackers from different manufacturers may have different operating logistics. If the AAT is paired to the HM30 ground unit via Bluetooth, then please ignore the wiring steps.

When the “Datalink Mode” is configured as Bluetooth, UDP, or Type-C, through the UART port on HM30 ground unit there will still be downloading data for antenna trackers. The antenna tracker baud rate can be changed according to your requirement.

# SIYI

## 4.4 Communication with Windows GCS through Type-C

### 4.4.1 QGroundControl

1. On HM30 ground unit, go to “Settings” and set “Type-C” for “Datalink Mode”, and configure the correct baud rate.
2. Make the Type-C connection between HM30 ground unit and the Windows device. HM30 ground unit will be recognized as a COM device in Windows system.
3. Run QGroundControl, go to “Application Settings - Comm Links” page, and “Add” a new connection. Name it as “Type-C”.

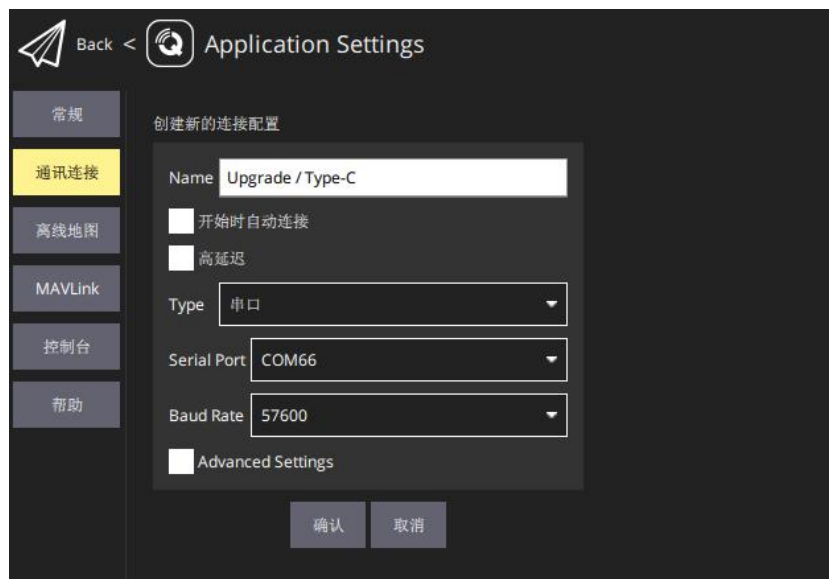

4. Set the connection “Type” as “Serial”. Match the baud rate.
5. Confirm and start to “Connect”. The top progress bar in QGC starts to move, which means the remote controller is communicate with QGC automatically. Please wait until the datalink connection is established.

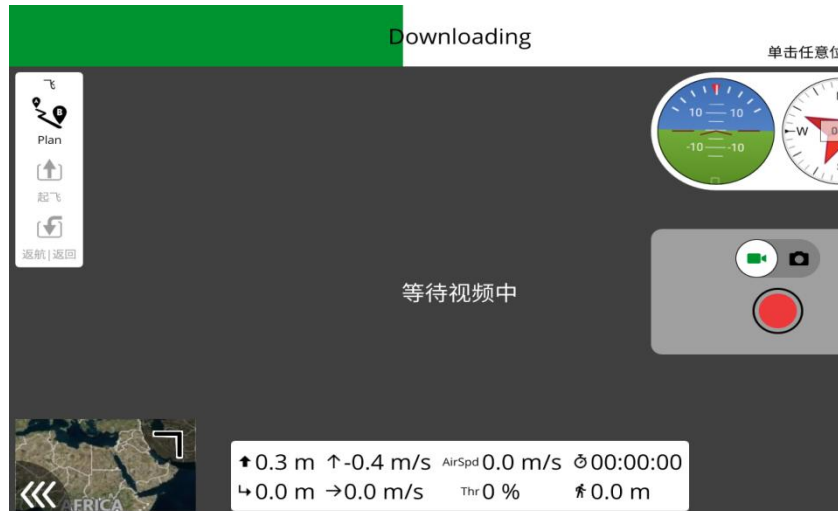

## Mark

If it is your first time to add a new connection in QGC, please do not check the option “Automatically Connect on Start”. It can be checked later when you confirm that the datalink is established successfully.

### 4.4.2 Mission Planner

1. On HM30 ground unit, go to “Settings” and set “Type-C” for “Datalink Mode”, and configure the correct baud rate.
2. Make the Type-C connection between HM30 ground unit and the Windows device. HM30 ground unit will be recognized as a COM device in Windows system.
3. Run Mission Planner, select the relevant port and match the baud rate.



4. Please wait until the datalink connection is established.



If the HM30 ground unit cannot be recognized as a COM device by your Windows device, please open “Computer – Manage – Device Manager”

# SIYI

and check if there were any abnormal drivers. If so, please download and install the relevant drivers to solve the issue.

## 4.5 Solutions to Disconnection

When the ground unit is in good communication with the air unit, but it fails to establish datalink connection with GCS, please try to follow the steps below for troubleshooting.

1. Confirm if the air unit is wired to the flight controller by correct telemetry cable.
2. If you are using a customized telemetry cable, please check:
  - If cable pin map is correct?
  - If the TX and RX pins in the flight controller and air unit telemetry port are swapped?
3. On HM30 ground unit, go to the “Datalink” page and check communication status. When the communication is good, “data download” is not 0. If it is “0”, please go back to check step 1 and 2.
4. In “Settings”, go to the “Datalink” option and check:
  - If the option is correct?
  - If “Baud Rate” matches with your flight controller?
  - In the GCS, check if the datalink settings are correctly configured.

# SIYI

5. If it is PX4 / ArduPilot open-source flight controller, please try to switch telemetry cable connection between the TELEM 1 port and the TELEM 2 port on flight controller.
6. If both the ground unit and air unit are the latest firmware?

## Mark

If you have done trouble shooting by following all steps above, but there are still no clues, please contact your reseller or SIYI after-sale service.

## 4.6 SIYI Datalink SDK

SIYI links can be integrated to customers' own network or ground station by acquiring SDK communication protocol.

### 4.8.1 Format

Field	Index	Bytes	Description
STX	0	2	0x5566: starting mark
CTRL	2	1	0: need_ack (if the current package need "ack") 1: ack_pack (if the package is an "ack" package) 2-7: Reserved
Data_len	3	2	Data field byte length. <b>Low byte in the front.</b>
SEQ	5	2	Frame sequence (0~65535) . <b>Low byte in the front.</b>
CMD_ID	7	1	Command ID
DATA	8	Data_len	Data
CRC16		2	CRC16 check to the complete data package. <b>Low byte in the front.</b>

# SIYI

## 4.8.2 Commands

### Request Hardware ID

CMD_ID:0x40 ----- Request Hardware ID			
Send data format			
No.	Data Type	Data Name	Data Description
ACK data format			
	uint8_t	hardware_id[12]	Hard ID String (10 digits)

Example:

Send (HEX): **55 66 01 00 00 00 00 40 81 9c**

Response (HEX): **55 66 02 0C 00 09 00 40 36 38 30 31 31 33 30 31 31 31 00 00 7b 8b**

### Request System Settings

CMD_ID:0x16 ----- Request Remote Controller System Settings			
Send data format (10 Hz)			
No.	Data Type	Data Name	Data Description
ACK data format			
	UInt8_t	match	Bind: 0: Start 1, 2: Binding 3: Finished
	UInt8_t	Baud_type	Telemetry Baud Rate: 0: BAUD_4800 1: BAUD_9600 2: BAUD_38400 3: BAUD_57600 4: BAUD_76800 5: BAUD_115200 6: BAUD_230400
	UInt8_t	Joy_type	Joystick Type: 0: Mode 1 1: Mode 2 2: Mode 3 3: Custom
	UInt8_t	Rc_bat	Ground Unit Battery Level x 10V

## Send System Settings Commands to Ground Unit

CMD_ID:0x17 ----- Send System Settings Commands to Ground Unit			
Send data format			
No.	Data Type	Data Name	Data Description
	UInt8_t	match	Bind: 0: Start 1, 2: Binding 3: Finished
	UInt8_t	Baud_type	Telemetry Baud Rate: 0: BAUD_4800 1: BAUD_9600 2: BAUD_38400 3: BAUD_57600 4: BAUD_76800 5: BAUD_115200 6: BAUD_230400
	UInt8_t	Joy_type	Joystick Type: 0: Mode 1 1: Mode 2 2: Mode 3 3: Custom
	UInt8_t	reserved	
ACK Data Format			
	int8_t	sta	1: ok Negative number means error



# SIYI

## Request Datalink Status

CMD_ID:0x43 ----- Request Datalink Status			
Send data format			
No.	Data Type	Data Name	Date Description
ACK data format			
	uint16_t	freq	Frequency
	uint8_t	pack_loss_rate	Loss Rate
	uint16_t	real_pack	Valid Package
	uint16_t	real_pack_rate	Valid Package Rate
	uint32_t	data_up	Data upload byte/s
	uint32_t	data_down	Data download byte/s

Example:

Send (HEX): 55 66 01 00 00 00 00 43 e2 ac

Response (HEX): 55 66 02 0F 00 01 00 43 02 00 00 02 00 02 00 00 00 00 00 00 00 00 00 00 00 00 2E 5C

## Request Image Transmission Link Status

CMD_ID:0x44 ----- Request Image Transmission Link Status			
Send data format			
No.	Data Type	Data Name	Data Description
ACK Data Format			
	int32_t	signal	Signal percentage: %
	int32_t	inactive_time	--
	int32_t	upstream	Data upload: byte/s
	int32_t	downstream	Data download: byte/s
	int32_t	txbandwidth	Upload bandwidth (txbandwidth / 1000 Mbps)
	int32_t	rxbandwidth	Download bandwidth (rxbandwidth / 1000 Mbps)
	int32_t	rssi	RF power: dBm
	int32_t	freq	Current frequency: Mhz
	int32_t	channel	Current Channel

Example:

Send (HEX): 55 66 01 00 00 00 00 44 05 dc

Response (HEX): 55 66 02 24 00 02 00 44 00 A4 15 00 00 6C 00 00 00 2C D9

## Request All Channel Mappings

CMD_ID:0x48 ----- Request All Channel Mappings			
Send data format			
No.	Data Type	Data Name	Data Description
ACK Data Format			
1	uint8_t	CH1_type	Physical Channel Type 0: Joystick, Dials 1: Buttons, Switches
1	uint8_t	CH1_entity_id	Physical Channel ID
2	uint8_t	CH2_type	Physical Channel Type 0: Joystick, Dials 1: Buttons, Switches
2	uint8_t	CH2_entity_id	Physical Channel ID
3	uint8_t	CH3_type	Physical Channel Type 0: Joystick, Dials 1: Buttons, Switches
3	uint8_t	CH3_entity_id	Physical Channel ID
4	uint8_t	CH4_type	Physical Channel Type 0: Joystick, Dials 1: Buttons, Switches
4	uint8_t	CH4_entity_id	Physical Channel ID
.....	uint8_t	.....	Current Channel

Example:

Send (HEX): 55 66 01 00 00 00 00 48 89 1d

Response (HEX): 55 66 02 20 00 16 00 48 00 00 00 01 00 02 00 03 05 00 05 01 05 02 01 00 01 01 01 02 01 03 00 04 00 05 02 01 02 00 03 00 C1 28

# SIYI

## Request A Specific Channel Mapping

CMD_ID:0x49 ----- Request A Specific Channel Mapping			
Send data format			
No.	Data Type	Data Name	Data Description
	uint8_t	rc_ch	RC Channel (1 to 16)
ACK Data Format			
1	uint8_t	rc_ch	RC Channel (1 to 16)
1	uint8	type	Physical Channel Type 0: Joystick, Dials 1: Buttons, Switches
2	uint8_t	entity_id	Physical Channel ID

Example:

Send (HEX): 55 66 01 01 00 00 00 49 02 4F 1C

Response (HEX): 55 66 02 03 00 17 00 49 02 00 01 33 9F

## MK15 Handheld Ground Station

Physical Channel	Type	entity_id	Channel Definition
Joystick	0	0	J1
	0	1	J2
	0	2	J3
	0	3	J4
Dial	0	4	LD
	0	5	RD
3-Stage Switch	5	0	SA
	5	1	SB
	5	2	SC
Button	1	0	A
	1	1	B
	1	2	C
	1	3	D
Virtual Channel	2	0	
No physical channel is mapped	3	0	NULL

# SIYI

## MK32 Handheld Ground Station

Physical Channel	Type	entity_id	Channel Definition
Joystick	0	0	J1
	0	1	J2
	0	2	J3
	0	3	J4
Dial	0	4	LD1
	0	5	RD1
	0	6	LD2
	0	7	RD2
3-Stage Switch	5	0	SA
	5	1	SB
	5	2	SC
	5	3	SD
	5	4	SE
	5	5	SF
Button	1	0	S1
	1	1	S2
Virtual Channel	2	0	
No physical channel is mapped	3	0	NULL

## Send Channel Mapping to Ground Unit

CMD_ID:0x4A ----- Send Channel Mapping to Ground Unit			
Send data format			
No.	Data Type	Data Name	Data Description
	uint8_t	rc_ch	RC Channel (1 to 16)
	uint8	type	Physical Channel Type 0: Joystick, Dials 1: Buttons, Switches
	uint8_t	entity_id	Physical Channel ID
ACK Data Format			
	uint8_t	rc_ch	RC Channel (1 to 16)
	int8_t	sta	1: OK Negative Number: Error Code

Example:

Send (HEX): 55 66 01 03 00 00 00 4A 02 00 00 4F EB

Response (HEX): 55 66 02 02 00 18 00 4A 02 01 4C C3

# SIYI

## Request All Channel Reverse

CMD_ID:0x4B ----- Request All Channel Reverse			
Send data format			
No.	Data Type	Data Name	Data Description
ACK Data Format			
1	int8_t	CH1_revers e	Reverse Channel 1 1: Normal -1: Reversed
2	int8_t	CH2_revers e	Reverse Channel 2 1: Normal -1: Reversed
3	int8_t	CH3_revers e	Reverse Channel 3 1: Normal -1: Reversed
4	int8_t	CH4_revers e	Reverse Channel 4 1: Normal -1: Reversed
5	int8_t	CH5_revers e	Reverse Channel 5 1: Normal -1: Reversed
.....	int8_t	.....	

Example:

Send (HEX): 55 66 01 00 00 00 00 4B EA 2D

Response (HEX): 55 66 02 10 00 19 00 4B 01 FF 01 01 01 01 01 01 01 01 01 01 01 01 01 01 01 01 01 D1 F9

## Request Channel Reverse

CMD_ID:0x4C ----- Request Channel Reverse			
Send data format			
No.	Data Type	Data Name	Data Description
	uint8_t	rc_ch	Channel 1 to 16
ACK Data Format			
1	uint8_t	rc_ch	Channel 1 to 16
2	int8_t	reverse	Channel Reverse 1: Normal -1: Reversed

Example:

Send (HEX): 55 66 01 01 00 00 00 4C 02 BA E3

Response (HEX): 55 66 02 02 00 1C 00 4C 02 FF 3B F6

## Send Channel Reverse to Ground Unit

CMD_ID:0x4D ----- Send Channel Reverse to Ground Unit			
Send data format			
No.	Data Type	Data Name	Data Description
	uint8_t	rc_ch	Channel 1 to 16
	int8_t	reverse	Channel Reverse 1: Normal -1: Reversed

Example:

Send (HEX): 55 66 01 02 00 00 00 4D 02 FF 0F 86

Response (HEX): 55 66 02 02 00 1D 00 4D 02 01 8B 65

## Request Firmware Version

CMD_ID:0x47 ----- Request Firmware Version			
Send data format			
No.	Data Type	Data Name	Data Description
ACK Data Format			
	uint32_t	rc_version	Remote controller function firmware version
	uint32_t	rf_version	Air unit function firmware version
	uint32_t	ground_version	Remote controller FPV firmware version
	uint32_t	sky_version	Air unit FPV firmware version

Mark:

The request firmware version is four bytes in hexadecimal, with the first byte in the low bit and the last byte in the high bit. The first byte is the product ID, and the remaining three bytes are the version number.

For example, 0x00 0x03 0x05 0x68, the product ID is 0x68, and the version number is 5.3.0. The same applies to other version numbers.

Example:

Send (HEX): 55 66 01 00 00 00 00 47 66 ec

Response (HEX): 55 66 02 10 00 02 00 47 00 03 05 68 07 02 05 69 02 02 00 56 02 02 00 56 6d

21

# SIYI

## 4.8.3 Communication Interface

SIYI datalink SDK supports four interfaces, which can be switched in SIYI TX app.

### 1) UART Serial Port

Port Name: /dev/ttyHS0

Baud Rate: 115200

### 2) USB COM (USB to Serial) (Baud rate is the same with datalink baud rate)

### 3) Bluetooth

### 4) MK15 RC Upgrade Port / MK32 RC Type-C Port (Virtual serial port based on USB port)

## 4.8.4 SDK CRC16 Check Code

```
const uint16_t crc16_tab[256];
```

```
/******  
CRC16 Coding & Decoding  $G(X) = X^{16} + X^{12} + X^5 + 1$   
*****/  
uint16_t CRC16_cal(uint8_t *ptr, uint32_t len, uint16_t crc_init)  
{  
    uint16_t crc, oldcrc16;  
    uint8_t temp;  
    crc = crc_init;  
    while (len--!=0)  
    {  
        temp=(crc>>8)&0xff;  
        oldcrc16=crc16_tab[*ptr^temp];  
        crc=(crc<<8)^oldcrc16;  
        ptr++;  
    }  
}
```

# SIYI

```
    }  
    //crc=~crc;    //??  
    return(crc);  
}
```

```
uint8_t crc_check_16bits(uint8_t* pbuf, uint32_t len, uint32_t* p_result)  
{  
    uint16_t crc_result = 0;  
    crc_result= CRC16_cal(pbuf, len, 0);  
    *p_result = crc_result;  
  
    return 2;  
}
```

```
const uint16_t crc16_tab[256]= {0x0,0x1021,0x2042,0x3063,0x4084,0x50a5,0x60c6,0x70e7,  
  
0x8108,0x9129,0xa14a,0xb16b,0xc18c,0xd1ad,0xe1ce,0xf1ef,  
  
0x1231,0x2210,0x3273,0x4252,0x52b5,0x6294,0x72f7,0x82d6,  
  
0x9339,0xa318,0xb37b,0xc35a,0xd3bd,0xe39c,0xf3ff,0xe3de,  
  
0x2462,0x3443,0x4420,0x5401,0x64e6,0x74c7,0x84a4,0x9485,  
  
0xa56a,0xb54b,0xc528,0xd509,0xe5ee,0xf5cf,0xc5ac,0xd58d,  
  
0x3653,0x4672,0x5611,0x6630,0x76d7,0x86f6,0x9695,0xa6b4,  
  
0xb75b,0xa77a,0x9719,0x8738,0xf7df,0xe7fe,0xd79d,0xc7bc,  
  
0x48c4,0x58e5,0x6886,0x78a7,0x8840,0x9861,0xa802,0xb823,  
  
0xc9cc,0xd9ed,0xe98e,0xf9af,0x8948,0x9969,0xa90a,0xb92b,  
  
0x5af5,0x4ad4,0x7ab7,0x6a96,0x1a71,0xa50,0x3a33,0x2a12,  
  
0xdbfd,0xcbdc,0xfbbf,0xeb9e,0x9b79,0x8b58,0xbb3b,0xab1a,  
  
0x6ca6,0x7c87,0x4ce4,0x5cc5,0x2c22,0x3c03,0xc60,0x1c41,  
  
0xedae,0xfd8f,0xcdec,0xddcd,0xad2a,0xbd0b,0x8d68,0x9d49,  
  
0x7e97,0x6eb6,0x5ed5,0x4ef4,0x3e13,0x2e32,0x1e51,0xe70,
```

# SIYI

0xff9f,0xefbe,0xdfdd,0xcffc,0xbf1b,0xaf3a,0x9f59,0x8f78,  
0x9188,0x81a9,0xb1ca,0xa1eb,0xd10c,0xc12d,0xf14e,0xe16f,  
0x1080,0xa1,0x30c2,0x20e3,0x5004,0x4025,0x7046,0x6067,  
0x83b9,0x9398,0xa3fb,0xb3da,0xc33d,0xd31c,0xe37f,0xf35e,  
0x2b1,0x1290,0x22f3,0x32d2,0x4235,0x5214,0x6277,0x7256,  
0xb5ea,0xa5cb,0x95a8,0x8589,0xf56e,0xe54f,0xd52c,0xc50d,  
0x34e2,0x24c3,0x14a0,0x481,0x7466,0x6447,0x5424,0x4405,  
0xa7db,0xb7fa,0x8799,0x97b8,0xe75f,0xf77e,0xc71d,0xd73c,  
0x26d3,0x36f2,0x691,0x16b0,0x6657,0x7676,0x4615,0x5634,  
0xd94c,0xc96d,0xf90e,0xe92f,0x99c8,0x89e9,0xb98a,0xa9ab,  
0x5844,0x4865,0x7806,0x6827,0x18c0,0x8e1,0x3882,0x28a3,  
0xcb7d,0xdb5c,0xeb3f,0xfb1e,0x8bf9,0x9bd8,0xabbb,0xbb9a,  
0x4a75,0x5a54,0x6a37,0x7a16,0xaf1,0x1ad0,0x2ab3,0x3a92,  
0xfd2e,0xed0f,0xdd6c,0xcd4d,0xbdaa,0xad8b,0x9de8,0x8dc9,  
0x7c26,0x6c07,0x5c64,0x4c45,0x3ca2,0x2c83,0x1ce0,0xcc1,  
0xef1f,0xff3e,0xcf5d,0xdf7c,0xaf9b,0xbfba,0x8fd9,0x9ff8,  
0x6e17,0x7e36,0x4e55,0x5e74,0x2e93,0x3eb2,0xed1,0x1ef0  
};

# SIYI

## CHAPTER 5 SIYI FPV APP

SIYI FPV is an Android application developed by SIYI to configure many SIYI products for video display, camera stream settings, and communication link status monitoring.

### **Mark**

This chapter is edited based on SIYI FPV App v2.5.15.691.

SIYI FPV App can be downloaded from SIYI official website:

<https://siyi.biz/en/index.php?id=downloads1&asd=192>

#### **SIYI FPV App compatible SIYI devices**

- ZT6 Mini Dual-Sensor Optical Pod
- SIYI AI Tracking Module
- ZT30 Four-Sensor Optical Pod
- ZR30 4K AI 180X Hybrid Zoom Optical Pod
- A2 mini Ultra-Wide-Angle FPV Gimbal
- MK32 / MK32E Enterprise Handheld Ground Station
- A8 mini AI Zoom Gimbal Camera
- ZR10 2K 30X Hybrid Zoom Optical Pod
- R1M HD Recording FPV Camera
- Air Unit HDMI Input Converter
- HM30 Full HD Image Transmission System
- MK15 / MK15E Mini Handheld Ground Station

# SIYI

## SIYI FPV App OSD Information Definition

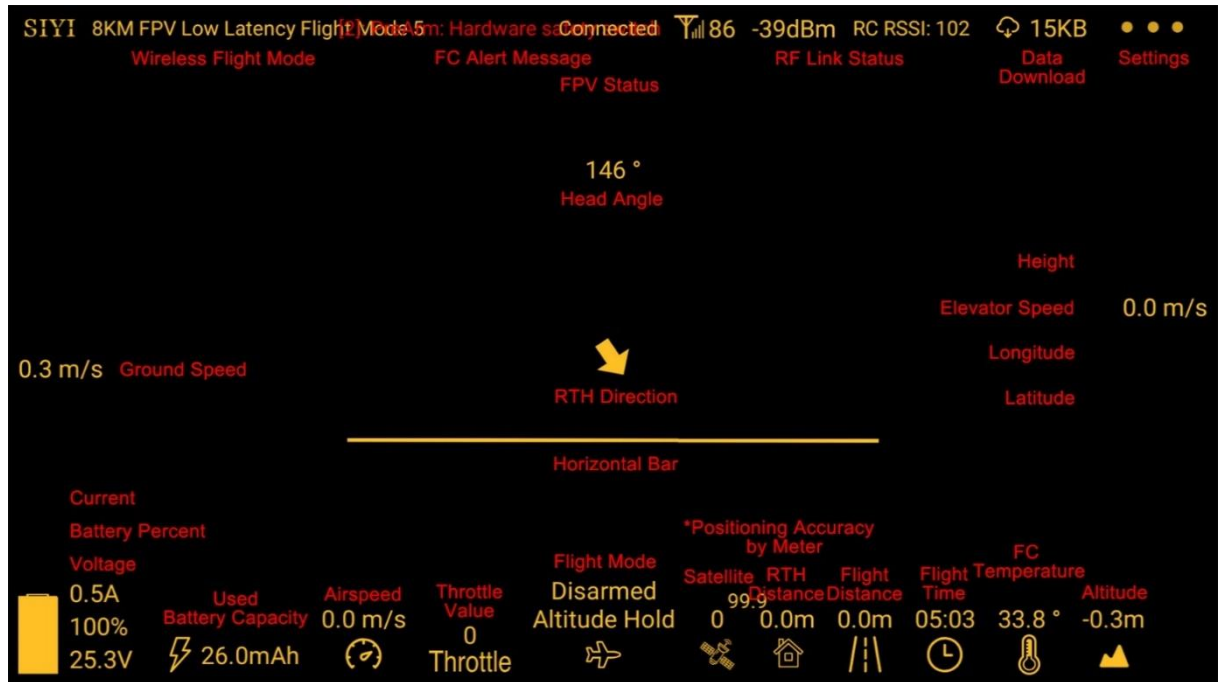

## SIYI FPV Camera Function Icon Definition



# SIYI

## 5.1 Settings

In “Settings” page, you can select camera type with stream type, select or input video stream IP addresses, custom app interface, and switch video decoding type.

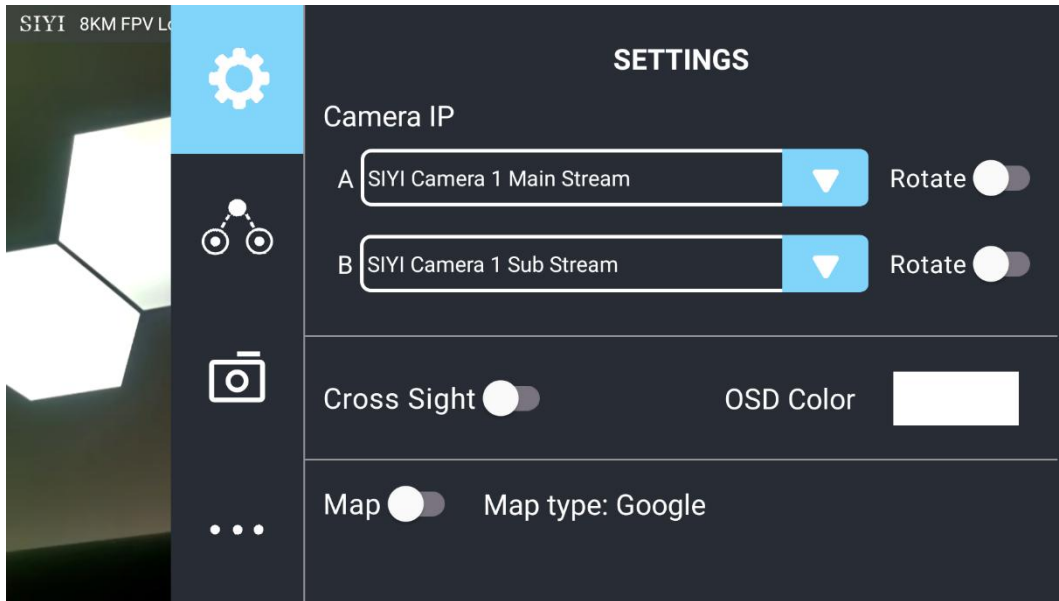

### About Settings

**Camera IP:** Select among SIYI AI Camera, SIYI Camera 1 and SIYI Camera 2, between main stream and sub stream, select or input video stream RTSP addresses, disable image, or rotate the relevant image in 180 degrees.

**Cross Sight:** Enable / disable a cross sight in the center of the image.

**OSD Color:** Custom the color of all OSD information.

**Map:** Enable / disable the map box over the left-bottom corner of the image.

# SIYI

Map Type: Switch map type (currently between Baidu and Google).

## 5.2 Link Status

Display the link status directly over the FPV image.

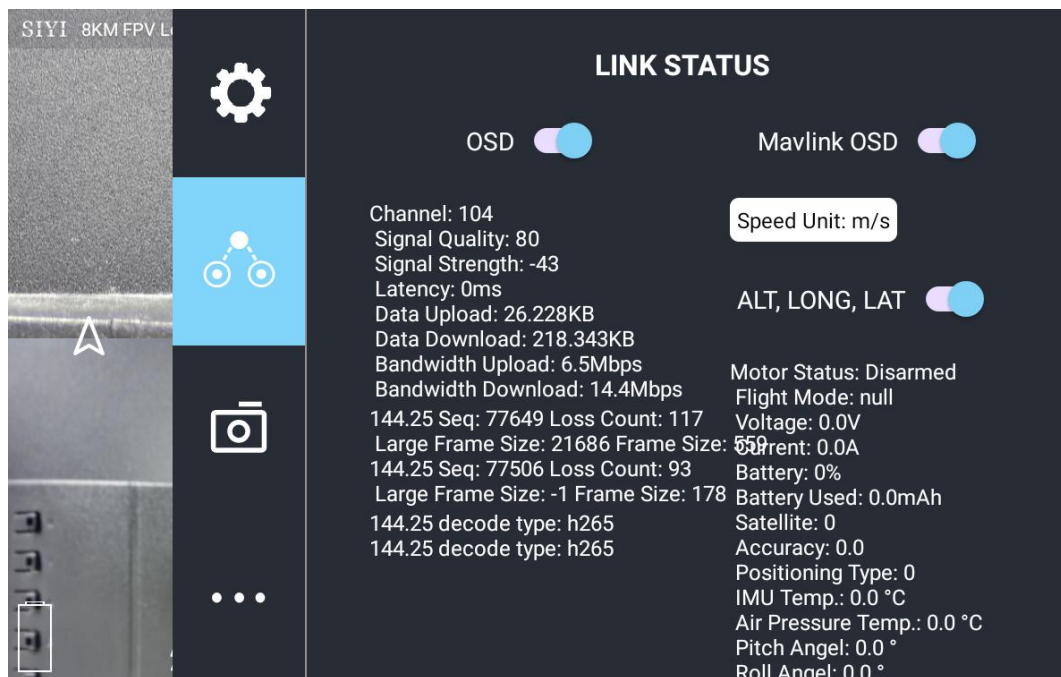

### About Link Status

OSD: Enable / disable standard OSD information.

Mavlink OSD: Enable / disable Mavlink OSD information.

Speed Unit: Switch speed unit between meter per seconds and kilometer per hour.

Longitude and Latitude: Enable / disable information.

## 5.3 Gimbal Camera

Configure the abundant functions of SIYI optical pod and gimbal camera.

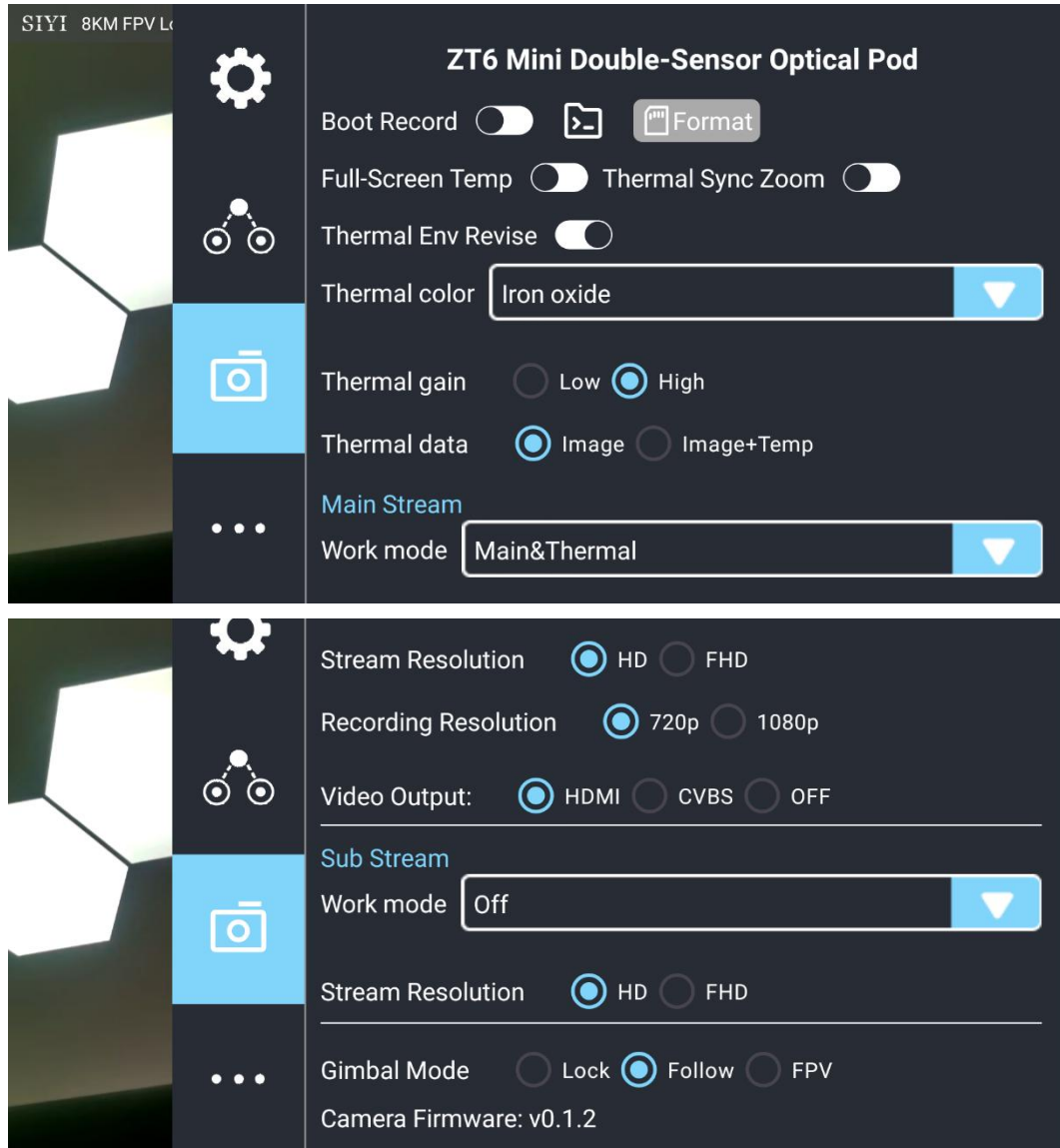

### About Gimbal Camera

**Boot Record:** Enable / disable automatic video recording by SD card as soon as the camera is powered.

**File Manager:** Preview stored images in TF card. Format the TF card.

**Laser Calibration:** The target position in the camera image may need to

# SIYI

be calibrated to match the accurate laser rangefinder orientation. (Only available for ZT30)

Full Image Thermometric: Enable / disable the full image temperature measurement feature in the thermal imaging camera.

Synchronize Zoom: Enable / disable simultaneous zooming of the thermal camera and the zoom camera.

Thermal Calibration: To calibrate the thermal camera by changing environment elements.

Thermal Palette: Assign different color solutions for the thermal imaging camera.

Thermal Gain: Switch between low gain and high gain for the thermal imaging camera.

Thermal RAW: Choose to include the RAW data in thermal images or not.

Main / Sub Stream: Configure the main stream and the sub stream separately for their camera source and parameters.

Image Mode: Select the video stream's image type and camera source.

Single image or split image. Zoom camera, wide angle camera, or thermal imaging camera.

Stream Resolution: Decide to switch the output resolution of the current video stream or not according to camera source. Max output resolution is Ultra HD (1080p).

# SIYI

Record Resolution: Decide to switch the recording resolution or not according to camera source. Max record resolution is 4K.

Video Output Port: Switch the video outputting ports.

- HDMI: Through the gimbal camera's Micro-HDMI port.
- CVBS: Through the CVBS pin in the gimbal camera's Ethernet port to output videos in analog signal (**Only available for ZT6 and A8 mini**).
- OFF: Through the gimbal camera's Ethernet only.

Gimbal Working Mode: Switch gimbal working mode among Lock Mode, Follow Mode, and FPV Mode.

- Lock Mode: Horizontally, gimbal does not follow when aircraft rotates.
- Follow Mode: Horizontally, gimbal follows when aircraft rotates.
- FPV Mode: Gimbal rotates simultaneously as aircraft rolls to get FPV view, and output images with enhanced stability.
- AI Tracking: When the gimbal is connected to the AI tracking module and the AI tracking function is activated. It will be AI tracking mode only.

Camera Firmware Version: Display current camera firmware version.

Gimbal Firmware Version: Display current gimbal firmware version.

Zoom Firmware Version: Display current gimbal firmware version (**Only available for optical zoom cameras**).

# SIYI

## 5.4 About SIYI FPV

Displays the software version of SIYI FPV and common contact information of SIYI Technology.

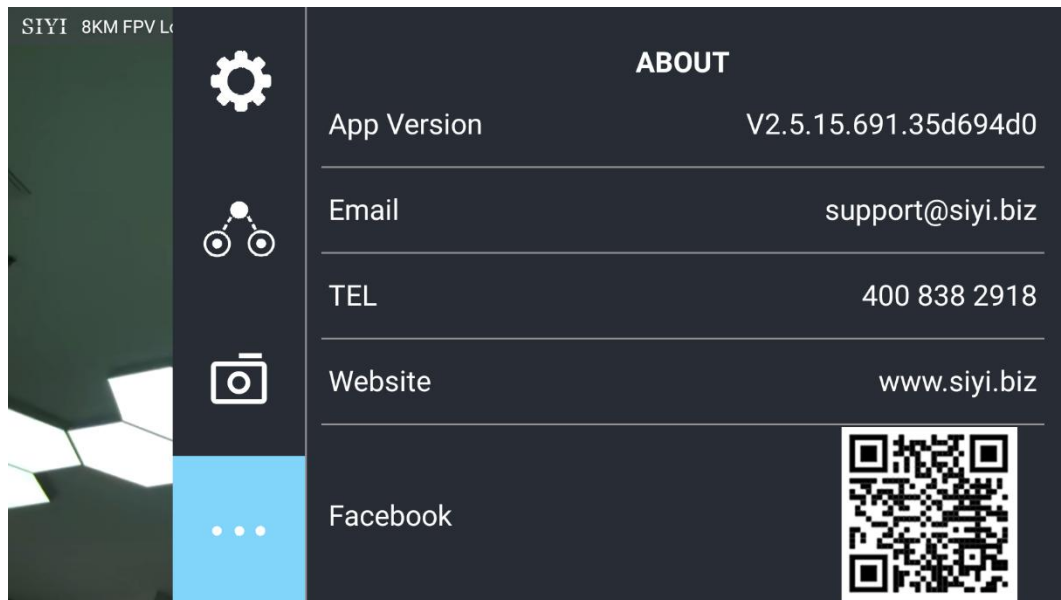

# SIYI

## 5.5 SIYI FPV App Update Log

<b>Date</b>	2024-01-26
<b>Version</b>	2.5.15.695
<b>Updates</b>	1. New: Support AI follow function.

<b>Date</b>	2023-12-18
<b>Version</b>	2.5.15.691
<b>Updates</b>	<ol style="list-style-type: none"><li>2. Fix: Temperature data still shows on image after switching to optical cameras from thermal camera.</li><li>3. New (A8 mini): Enable OSD watermark on recording images.</li><li>4. New: Both video streams can turn on / off recording.</li><li>5. New (SIYI AI Tracking Module): A switch for flight tracking.</li><li>6. New (Thermal): A switch for thermal gain.</li><li>7. New (Thermal): A switch for thermal calibration.</li><li>8. New (Thermal): A switch for thermal RAW.</li><li>9. Fix: Camera control interface bug when two different cameras are plugged.</li></ol>

<b>Date</b>	2023-10-20
<b>Version</b>	2.5.15.679
<b>Updates</b>	<ol style="list-style-type: none"><li>1. New: AI recognition and tracking function control interface.</li><li>2. New (ZT30): Zoom &amp; thermal camera simultaneous recording function control interface.</li><li>3. New: Add the AI tracking module to IP addresses settings.</li><li>4. Improve: Occasionally video stream does not recover when the link is disconnected under SIYI camera protocol.</li></ol>

<b>Date</b>	2023-08-24
<b>Version</b>	2.5.15.660
<b>Updates</b>	<ol style="list-style-type: none"><li>1. New (ZT30): Laser calibration. Display laser ranging target's coordinates.</li><li>2. New: Support TF format.</li><li>3. New (ZT30): Thermal color palette.</li><li>4. New: File manager to preview stored pictures in TF card.</li><li>5. Improve: New icon indication for missing TF card.</li></ol>

<b>Date</b>	2023-07-31
<b>Version</b>	2.5.14.644
<b>Updates</b>	<ol style="list-style-type: none"><li>1. New: Status indication for successfully integrated flight controller attitude data.</li><li>2. New: Google map is supported.</li><li>3. Fix: Flight controller location was no accurate. New icons for flight controller location and device location.</li><li>4. New: Status indication for missing TF card.</li></ol>

# SIYI

## 5.6 SIYI FPV SDK Guide

SIYI provides the SIYI FPV SDK to help professional Android application developers to integrate the unique features in SIYI FPV app to their own GCS.

### 5.6.1 Access Method

#### a) Add “fpvlib” into Your Project

Copy the “fpvlib.aar” file to the “libs” folder in your “module” like below:

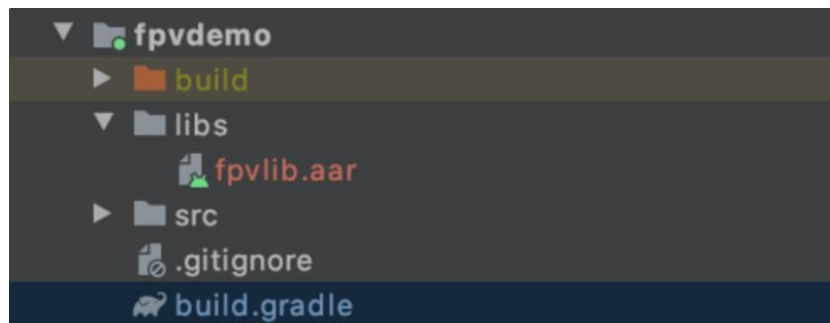

Revise the “build.gradle” file:

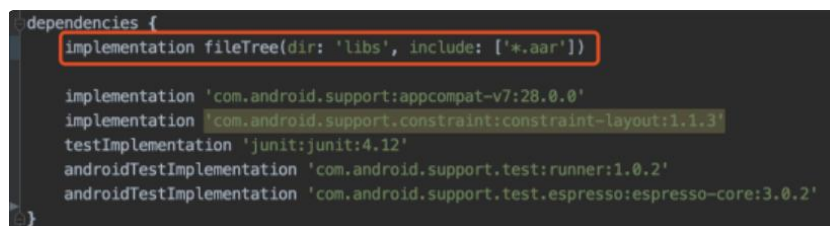

#### b) Configure “AndroidManifest” File

Add USB reading authorization to the “AndroidManifest” file in your “module” and configure the “intent-filter” file.

```

package="com.siyi.fpvdemo">
<uses-feature android:name="android.hardware.usb.host"/>

<application
    android:allowBackup="true"
    android:icon="@mipmap/ic_launcher"
    android:label="fpvdemo"
    android:roundIcon="@mipmap/ic_launcher_round"
    android:supportsRtl="true"
    android:theme="@style/AppTheme">
    <activity android:name=".MainActivity"
        android:launchMode="singleTask"
        android:screenOrientation="landscape">
        <intent-filter>
            <action android:name="android.intent.action.MAIN" />

            <category android:name="android.intent.category.LAUNCHER" />
        </intent-filter>
        <intent-filter>
            <action android:name="android.hardware.usb.action.USB_DEVICE_ATTACHED" />
        </intent-filter>
        <meta-data android:name="android.hardware.usb.action.USB_DEVICE_ATTACHED"
            android:resource="@xml/usb_device_filter" />

        <intent-filter>
            <action android:name="android.hardware.usb.action.USB_ACCESSORY_ATTACHED" />
        </intent-filter>
        <meta-data android:name="android.hardware.usb.action.USB_ACCESSORY_ATTACHED"
            android:resource="@xml/usb_accessory_filter" />
    </activity>

```

## c) Add FPV Display Function into Code

### Add JNI Library

Like the example below, add JNI library file into the “main” directory, then the “so” library file can be copied from “demo” to your project directory.

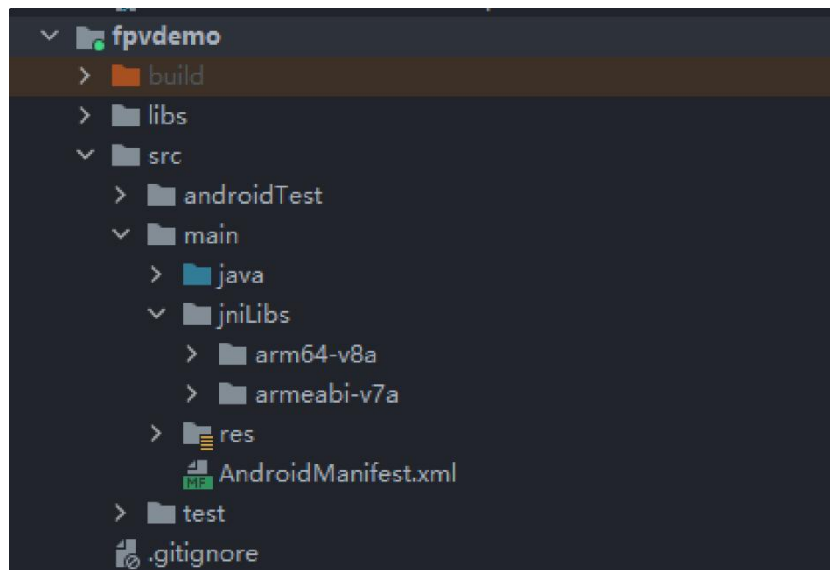

### Add FPV Video Display to Code

Please pay attention to the below points for your code:

- Firstly, use the static method “getInstances()” of “ConnectionManager” to get the “ConnectionManager” object. Then call the “ConnectionManager.checkConnectWithIntent()” method in the lifecycle method “onCreate()” and “onNewIntent()”.
- Video stream should be displayed through “SurfaceView”. So, we create an “SurfaceView” object and need to call “ConntionManager.notifySurfaceCreate()” and “notifySurfaceDestroy” method from “surfaceCreated()” and

# SIYI

“surfaceDestroy()”.

```
mSurfaceView.getHolder().addCallback(new SurfaceHolder.Callback() {  
    @Override  
    public void surfaceCreated(SurfaceHolder holder) {  
        Logcat.d(TAG, "onSurfaceCreated...");  
        mConnectionManager.notifySurfaceCreate(holder.getSurface());  
    }  
    @Override  
    public void surfaceChanged(SurfaceHolder holder, int format, int width  
, int height) {  
    }  
    @Override  
    public void surfaceDestroyed(SurfaceHolder holder) {  
        mConnectionManager.notifySurfaceDestroy(holder.getSurface());  
    }  
});
```

- Dual-Channel FPV Display:

Dual-channel FPV display supports Ethernet connection only. It does not support AOA or USB connection. For dual-channel FPV display, we should configure the IP addresses first, then create two “SurfaceView” for image display. Whether the second video stream is required or not can be judged by the connection type through connection status. You can refer to “demo” for detail.

- When you quit the application, please do not forget to call the “UsbConnectionManager.release()” method.

For more detail, please refer to the codes in “demo”.

# SIYI

## 5.6.2 Interface Instructions

### ConnectionManager

Name	Description
getInstance(Context context)	Single case method for “ConnectionManager”
setWirelessUrl(String url1, String url2)	Set the addresses for video stream.
checkConnectWithIntent(Intent intent)	Initial the connection.
notifySurfaceCreate(Surface surface)	Notify that the first “Surface” is created, the “Surface” is for video display.
notifySurfaceDestroy(Surface surface)	Notify that the first “Surface” is destroyed.
notifySecondSurfaceCreate(Surface surface)	Notify that the second “Surface” is created, the “Surface” is for video display.
notifySecondSurfaceDestroy(Surface surface)	Notify that the second “Surface” is destroyed.
setConnectionListener(ConnectionListener listener)	Set callback for the connection status.
setFrameListeners(FrameListener frameListener, FrameListener secondFrameListener)	Set callback for video stream.
getSDKVersion()	Request SDK version.
release()	Release SDK.

# SIYI

## SettingsConfig

Name	Description
SettingsConfig.getInstance().initConfig(context)	<b>Initialize the settings. This method must be called.</b>
setLogEnable(boolean)	Set if print the log in the sdk. It is suggested to disable print in the “release” version.
setDecodeType(Context context, @IDecodeListener.DecodeType decodeType) int	Set decoding type. In default it is hardware decoding.
setSupportWirelessConnection(Context context, boolean supportWireless)	Set if to support Ethernet connection method.
setRectify(Context context, boolean rectify)	<p>Set if to activate the video stream distortion correction function. The function is disabled in default and is only for A2 mini FPV gimbal at this moment. It works only when the video stream addresses is “RtspConstants.DEFAULT_TCP_VIDEO_URL” “SUB_TCP_VIDEO_URL”.</p> <p>Attention :</p> <p>If distortion correction is activated, when you switch from SIYI camera addresses “RtspConstants.DEFAULT_TCP_VIDEO_URL” “SUB_TCP_VIDEO_URL” to RTSP addresses, new surface objects should be imported. One way to do this is to remove “SurfaceView” and add a new “SurfaceView” through “addView”, then import the “Surface” object again in “SurfaceHolder.Callback”.</p>
getCameraManager()	Request camera control objects. SYSDKCameraManager

# SIYI

## SYSDKCameraManager

Name	Description
<pre>/**  * Set Camera Resolution  * @param streamType :  * [CameraInfo.STREAM_MAIN],  [CameraInfo.STREAM_SUB].  * @param resolution :  [CAMERA_RESOLUTION_SD] 480p,  [CAMERA_RESOLUTION_HD] 720p,  [CAMERA_RESOLUTION_FHD] 1080p.  * [CAMERA_RESOLUTION_2K] 2K,  [CAMERA_RESOLUTION_4K] 4K,  */ fun setResolution(cameraIndex: Int,  @CameraInfo.StreamType streamType:  Int,  @CameraResolution resolution: Int)</pre>	Set camera resolution.

# SIYI

## 5.7 SIYI FPV SDK Update Log

<b>Version</b>	2.5.15
<b>Updates</b>	<ol style="list-style-type: none"><li>1. Fix the issue that RTSP stream may blurr.</li><li>2. Add camera control interface.</li><li>3. Fix some other known issues.</li></ol> <p>Mark: It is necessary to update the “so” and “aar” file, which can be updated frm the “aar_so” folder.</p>

<b>Version</b>	2.5.14
<b>Updates</b>	<ol style="list-style-type: none"><li>1. Fix some issues which causes anormal in JNI library (need to update “so” library).</li><li>2. Fix some other known issues.</li></ol> <p>Mark: It is necessary to update the “so” and “aar” file, which can be updated frm the “aar_so” folder.</p>

<b>Version</b>	2.5.13
<b>Updates</b>	<ol style="list-style-type: none"><li>1. Fix the issue that the video stream of some IP65 cameras may blurr.</li><li>2. Add to support ZT30 camera video stream.</li></ol> <p>Mark: It is necessary to update the “so” and “aar” file, which can be updated frm the “aar_so” folder.</p>

# SIYI

## CHAPTER 6 IMAGE TRANSMISSION

SIYI MK32 / HM30 / MK15 links support up to 1080p resolution, 60 fps, and real-time image transmission with a latency as low as 150 milliseconds. It is suitable for SIYI optical pods and gimbal cameras and supports connecting to third-party optical pods and gimbal cameras. The external air unit HDMI input converter can be expanded to support cameras with HDMI input. The external multi-camera adapter module (FPV Hub) can expand the connection to support multiple video stream inputs.

### **6.1 Enable AI Recognition & Tracking through SIYI AI Tracking Module Using SIYI Optical Pod (Gimbal Camera) and SIYI Link**

SIYI optical pod (gimbal camera) can connect to SIYI link through SIYI AI tracking module and enable AI recognition and tracking feature through SIYI FPV app or SIYI QGC app while the air unit is communicating with the ground unit.

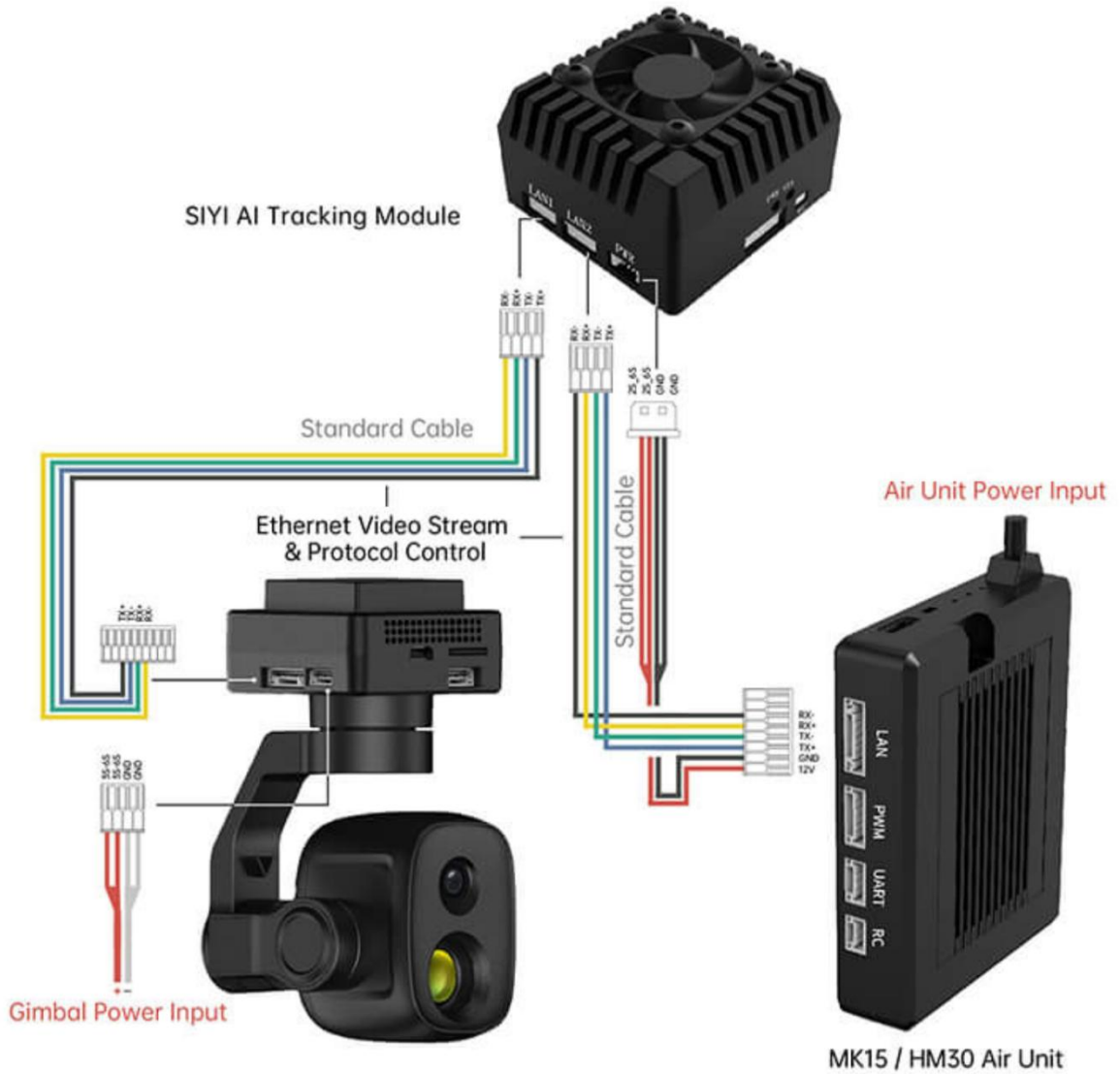

## Steps

1. Please refer to the above picture to connect SIYI AI tracking module with SIYI gimbal and SIYI link.
2. Confirm if gimbal camera's firmware has been upgraded to be compatible with SIYI AI tracking module.

# SIYI

3. Confirm if SIYI FPV app has been upgraded to be compatible with SIYI AI tracking module.
4. Run SIYI FPV app, go to “Settings - Addresses”, and select “SIYI AI Camera”.

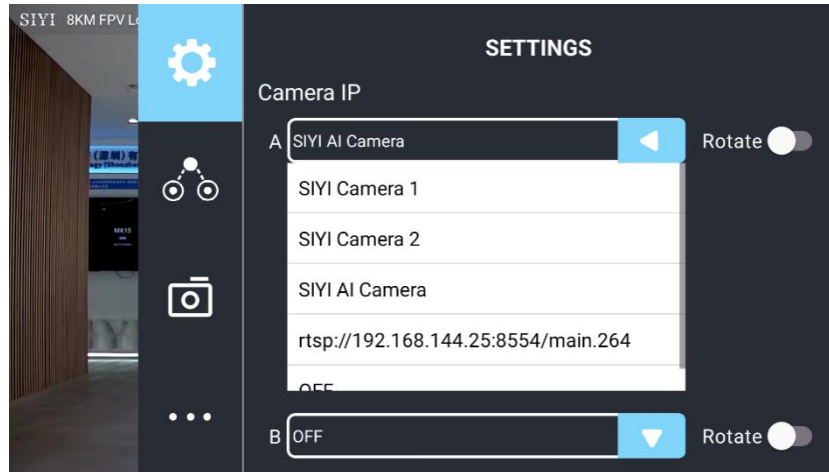

5. Return to main image, touch the AI tracking function button to enable the function.



6. Touch the button again to disable the function.

# SIYI



Using SIYI AI tracking module with multiple-sensor optical pods, in SIYI FPV app, the main stream of the optical pod should be configured as zoom camera.

## 6.2 Control SIYI Optical Pod (Gimbal Camera) in SIYI FPV App or SIYI QGC App through SIYI link

SIYI optical pod (gimbal camera) can connect to SIYI link directly to control gimbal rotation, gimbal functions, and video display in SIYI FPV app or SIYI QGC app when the air unit is communicating with the ground unit.



# SIYI

## 6.2.1 Preparation

It is necessary to prepare the tools, firmware, and software below before controlling gimbal camera in this way.

- SIYI Links (MK32 Standard Combo / HM30 / MK15 Enterprise Standard Combo is suggested for excellent compatibility with SIYI gimbal cameras)
- SIYI Optical Pod (Gimbal Camera)

### Mark

Above products can be purchased from SIYI directly or from SIYI authorized dealers.

- SIYI Gimbal to SIYI Link Cable

### Mark

Above tools come with product package.

- SIYI FPV App (v2.5.15.691 or latest version)
- SIYI QGC App

### Mark

Above software can be downloaded from relevant product page on SIYI

# SIYI

official website.

## **SIYI FPV App Steps**

1. Power the air unit and bind it with the ground unit.
2. Use SIYI Gimbal to SIYI Link Cable to connect the air unit's Ethernet port to the gimbal camera's Ethernet port.
3. Update SIYI FPV app to the latest.
4. Run SIYI FPV app, go to "Settings" and select the relevant SIYI camera type with main / sub stream, video stream will display. Gimbal motion and camera functions can be controlled by the application.

## **SIYI QGC App Steps**

1. Power the air unit and bind it with the ground unit.
2. Use SIYI Gimbal to SIYI Link Cable to connect the air unit's Ethernet port to the gimbal camera's Ethernet port.
3. Run SIYI QGC app, go to "Comm Links – Video Settings", and select "RTSP Video Stream" for "Source", then enter the default RTSP addresses of SIYI gimbal camera, video stream will display. Gimbal motion and camera functions can be controlled by the application.

# SIYI

## 6.2.2 Gimbal Pitch and Yaw Rotation

While SIYI FPV App or SIYI QGC app is running,

Sliding on touchscreen can control gimbal rotation. Sliding left and right are yaw rotation, up and down are gimbal pitch rotation.

Double tap touchscreen, gimbal will automatically center.

### Mark

Slide on touchscreen and hold it, gimbal will continue rotating till it reaches physical limit. Farther that you hold it from the center of the screen, faster the gimbal rotates.

## 6.2.3 Zoom and Focus

While SIYI FPV App or SIYI QGC app is running,

Touching “Zoom in” or “Zoom out” icon on can control the zoom camera.

Click the touchscreen once, optical zoom gimbal camera will focus automatically.

## 6.2.4 Take pictures and Record Video

While SIYI FPV App or SIYI QGC app is running,

# SIYI

Touch “Photo” icon once on to take a picture. Touch “Record” icon to start video recording. Touch “Recording” icon to stop video recording.

## Mark

Before taking a picture or recording video, it is necessary to insert SD card into the camera.

### 6.3 Control SIYI Optical Pod (Gimbal Camera) in SIYI QGC (Windows) Software through SIYI Link

SIYI optical pod (gimbal camera) can connect to SIYI link directly to control gimbal rotation, gimbal functions, and video display in SIYI QGC Windows software when the air unit is communicating with the ground unit.



# SIYI

## 6.3.1 Preparation

It is necessary to prepare tools, firmware, and software below before controlling gimbal camera in this way.

- SIYI Links (MK32 Standard Combo / HM30 / MK15 Enterprise Standard Combo is suggested for excellent compatibility with SIYI gimbal cameras)
- SIYI Optical Pod (Gimbal Camera)

### Mark

Above products can be purchased from SIYI directly or from SIYI authorized dealers.

- SIYI Gimbal to SIYI Link Cable

### Mark

Above tools come with product package.

- SIYI QGC Windows Software

### Mark

Above software can be downloaded from relevant product page on SIYI official website.

# SIYI

## Steps

1. Power the air unit and bind it with the ground unit.
2. Use SIYI Gimbal to SIYI Link Cable to connect the air unit's Ethernet port with the gimbal's Ethernet port.
3. Then connect the ground unit of the SIYI link to the Windows computer.
4. Modify the computer's Ethernet settings to have the same gateway with SIYI link and avoid IP addresses conflict.

For example, let's assign "192.168.144.30" for the computer IP addresses.



5. Run SIYI QGC Windows software, go to "Comm Links – Video Settings", and select "RTSP Video Stream" for "Source", then enter

# SIYI

the default RTSP addresses of SIYI gimbal camera, video stream will display. Gimbal motion and camera functions can be controlled by mouse in QGroundControl.

## 6.3.2 Gimbal Pitch and Yaw Rotation

While SIYI QGC Windows software is running,

Drag the mouse on screen can control gimbal rotation. Dragging the mouse left and right are yaw rotation, up and down are pitch rotation.

Double click the mouse on screen, gimbal will automatically center.

### Mark

Drag the mouse on screen and hold it, gimbal will continue rotating unless there is a physical stop. Farther you hold it from the center of the screen, faster the gimbal rotates.

## 6.3.3 Zoom and Focus

While SIYI QGC Windows software is running,

Clicking “Zoom in” or “Zoom out” icon on can control the zoom camera.

Click on screen, optical zoom camera will focus automatically.

# SIYI

## 6.4.4 Take pictures and Record Video

While SIYI QGC Windows software is running,

Click “Photo” icon once on to take a picture. Click “Record” icon to start video recording. Click “Recording” icon to stop video recording.

### Mark

Before taking a picture or recording video, it is necessary to insert SD card into gimbal camera.

## 6.4 Control SIYI Optical Pod (Gimbal Camera) by S.Bus Signal and Forward S.Bus Signal to Flight Controller through SIYI Link

SIYI optical pod (gimbal camera) can be connected to the air unit of SIYI link and the flight controller simultaneously for attitude control through joysticks, dials, switches, and buttons on a remote controller or on an SIYI handheld ground station.



## 6.4.1 Preparation

It is necessary to prepare tools, firmware, and software below before controlling gimbal camera in this way.

- SIYI Links (MK32 Standard Combo / HM30 / MK15 Enterprise Standard Combo is suggested for excellent compatibility with SIYI gimbal cameras)
- SIYI Optical Pod (Gimbal Camera)

### Mark

Above products can be purchased from SIYI directly or from SIYI authorized dealers.

- SIYI Gimbal to SIYI Link Cable
- 3 in 1 Control Cable (For ZT30, ZT6, ZR30, and A8 mini)
- MK15 / HM30 Air Unit S.Bus Y Cable

# SIYI

## Mark

Above tools come with product package.

- Cable (USB-C to USB-A)

## Mark

Above tools should be prepared by customer.

- SIYI PC Assistant (v1.3.9 or latest version)

## Mark

Above software can be downloaded from relevant product page on SIYI official website.

## Steps

1. Power the air unit and bind it with the ground unit.
2. Use SIYI Gimbal to SIYI Link Cable to connect the air unit's Ethernet port with gimbal's Ethernet port.
3. Wire the 3 in 1 Control Cable with the MK15 / HM30 Air Unit S.Bus Y Cable.
4. Then use the combined cable to connect the air unit's RC port and the gimbal's control signal port.

# SIYI

5. Install and run SIYI PC Assistant on Windows computer.
6. Use the USB-C to USB-A cable to connect the gimbal to the computer, then run SIYI PC Assistant and go to “Gimbal Config” page.

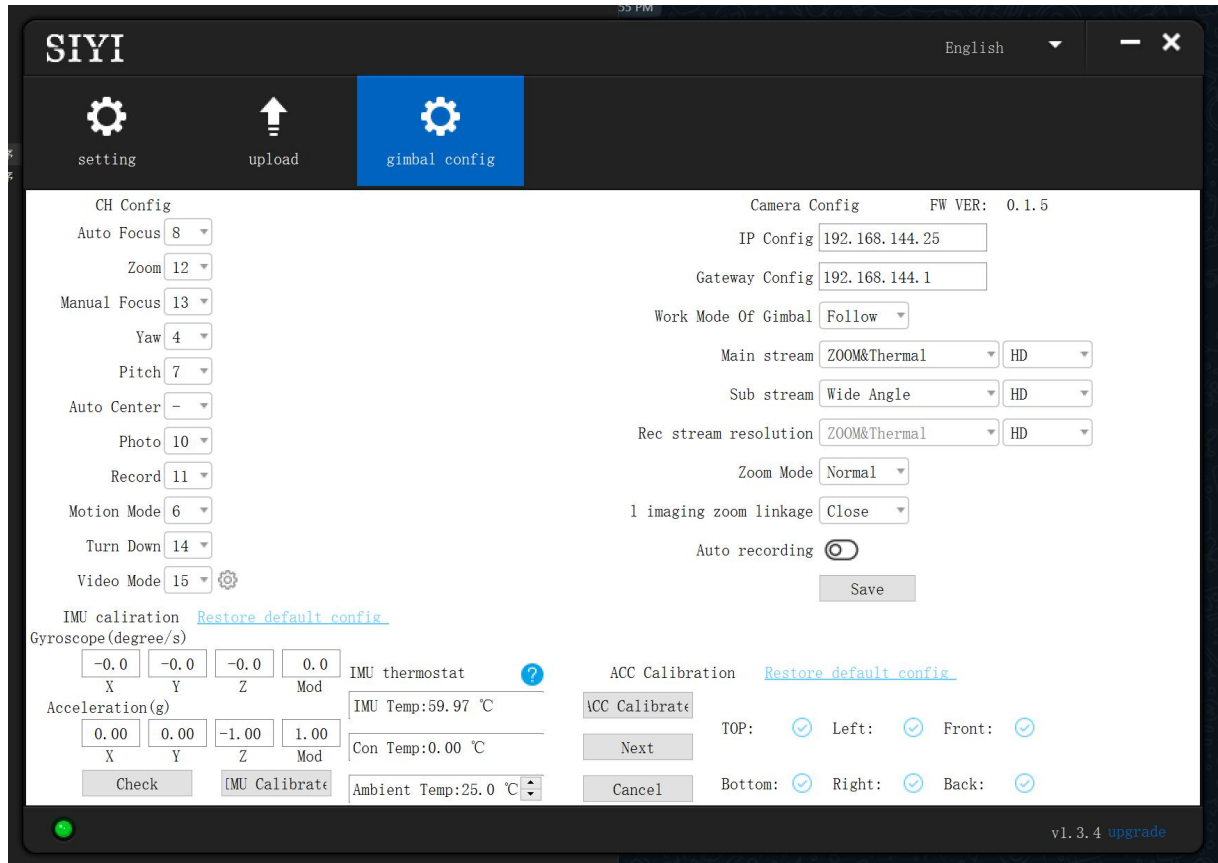

7. Under “Channel Config” page, assign the communication channel 1 to 16 to target gimbal and camera functions according to your requirement.
8. For the assigned channels, operate their mapped joysticks, dials, switches, and buttons on the handheld ground station to confirm if they are working normally.

# SIYI

## 6.4.2 Gimbal Pitch and Yaw Rotation (Taking an example of Dial Control)

Below is suggested channel mapping settings for testing, customers are free to assign channel mappings as required through SIYI TX app.

- Channel 7 = Left Dial (Reversed)
- Channel 8 = Right Dial
- Channel 12 = Any Button

In SIYI PC Assistant, map “Yaw” function to channel 7 and “Pitch” to channel 8, “Center” to channel 12.

Then, if you operate the left dial, gimbal will rotate on yaw axis. If you operate the right dial, gimbal will rotate on pitch axis. Press the button, gimbal will center itself automatically.

### **Mark**

Hold the dial from its center position, gimbal will keep rotating unless there was a physical limit. Farther you hold it away from center, faster gimbal rotates.

# SIYI

## 6.4.3 Zoom (Taking an Example of Switch Control)

Below are the suggested channel mapping settings for testing, customers are free to assign channel mappings as required through SIYI TX app.

- Channel 13 = A Switch

In SIYI PC Assistant, map “Zoom” function to channel 13.

Then, if you operate the switch, camera will zoom in or zoom out.

## 6.4.4 Take Pictures and Record Video (Taking an Example of Button Control)

Below are the suggested channel mapping settings for testing, customers are free to assign channel mappings as required through SIYI TX app.

- Channel 9 = Button A
- Channel 10 = Button B

In SIYI PC Assistant, map “Photo” function to channel 9 and “Record” to channel 10.

Then, if you press button A, camera will take a picture. If you press button B, camera will start or stop video recording.



Before taking pictures or recording video, it is necessary to insert SD card into the camera.

## 6.5 Connect Third-Party Ethernet Cameras to SIYI Link

Before connecting a third-party Ethernet camera to SIYI link, please change its IP address to “192.168.144.X”.



The “X” should not be “11”, “12”, or “20”, otherwise it won’t work. The three addresses have been occupied by the ground unit, the air unit, and Android system of SIYI handheld ground station.

Let’s take QGroundControl as an example.

1. In camera settings, check and copy the RTSP addresses from your camera.
2. In QGC, go to “General” page and slide to “Video Settings”.

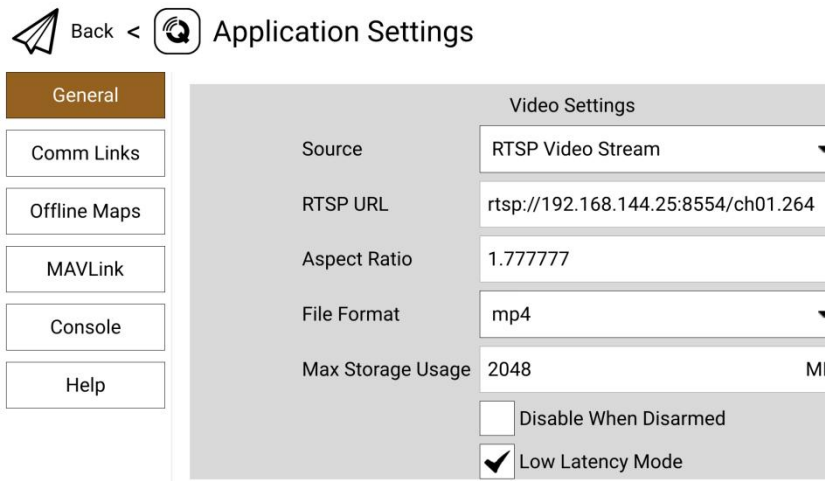

3. Configure “Source” as “RTSP Video Stream”. Then input the copied RTSP addresses of your camera after the “RTSP URL”.
4. Go back to QGC home page to check video display.

## 6.6 Connect HDMI Cameras to SIYI Link

Cameras which support HDMI output only must go through the SIYI air unit HDMI input converter to connect to SIYI air unit. Please refer to the steps below.

Let’s take QGroundControl as an example.

1. Open QGC, go to “General” page and slide to “Video Settings”.
2. Configure “Source” as “RTSP Video Stream”. Then input the SIYI air unit HDMI input converter’s RTSP addresses after the “RTSP URL”.
3. Go back to QGC home page to check video display.

# SIYI

## **6.7 Connect Dual Video Stream to SIYI Link**

Dual video streams from two different cameras must go through the FPV hub to connect the SIYI air unit. There are multiple ways to do so.

### **6.7.1 Dual SIYI Cameras or Dual SIYI Air Unit HDMI Input Converters**

Please assign different IP addresses for the two cameras or converters, such as “192.168.144.25” and “192.168.144.26”. Then connect both cameras to the FPV Hub and opening SIYI FPV app, you can see dual video stream when after configuring IP Addresses.

### **6.7.2 Dual Third-Party Ethernet Cameras**

Make sure that the two Ethernet cameras use different IP addresses and connect them to the FPV Hub. Then open SIYI FPV app, input their RTSP addresses, and you will see two video streams.

### **6.7.3 SIYI HDMI Converter and Third-Party Ethernet Camera**

Make sure that the IP camera use a different IP address from the HDMI converter and connect them to the FPV Hub. Then open SIYI FPV app,

# SIYI

input their RTSP addresses, and you will see two video streams.

## **Mark**

Dual video stream does not work when the two streams use the same IP addresses.

For more details about the IP addresses of SIYI links and cameras, please refer to the chapter 6.8 in this manual.

## **6.8 Common IP Addresses**

SIYI Air Unit IP Address: 192.168.144.11

SIYI Ground Unit IP Address: 192.168.144.12

SIYI Handheld Ground Station Android System IP Address:  
192.168.144.20

SIYI AI Camera IP Address: 192.168.144.60

SIYI Optical Pod / Gimbal Camera's Default IP Addresses:  
192.168.144.25

(NEW) SIYI Optical Pod / Gimbal Camera's Default RTSP Addresses:

- SIYI AI Camera: rtsp://192.168.144.25:8554/video0
- Main Stream: rtsp://192.168.144.25:8554/video1
- Sub Stream: rtsp://192.168.144.25:8554/video2

# SIYI

(NEW) SIYI FPV App's Private Video Stream Protocol's Addresses:

- SIYI Camera 1 Main Stream: 192.168.144.25: 37256
- SIYI Camera 1 Sub Stream: 192.168.144.25: 37255
- SIYI Camera 2 Main Stream: 192.168.144.26: 37256
- SIYI Camera 2 Sub Stream: 192.168.144.26: 37255

SIYI IP67 Camera A's IP Address: 192.168.144.25

SIYI IP67 Camera B's IP Address: 192.168.144.26

SIYI Air Unit HDMI Input Converter's IP Address: 192.168.144.25

SIYI IP67 Camera A's RTSP Address:

rtsp://192.168.144.25:8554/main.264

SIYI IP67 Camera B's RTSP Address:

rtsp://192.168.144.26:8554/main.264

SIYI Air Unit HDMI Input Converter's RTSP Address:

rtsp://192.168.144.25:8554/main.264

Common Video Player: SIYI FPV, QGroundControl, EasyPlayer

Network Diagnosis Tool: Ping Tools

## **Mark**

SIYI cameras released after ZT30 (including ZT30 and ZT6) start to use the new addresses.

# SIYI

SIYI cameras released before ZT30 (including ZR30, A2 mini, A8 mini, ZR10, and R1M) are stilling using the old addresses.

## 6.9 Solutions to No Image

If the video stream cannot be displayed properly through SIYI link, please follow the steps below to investigate possible reasons.

1. Check connection.
  - If the ground unit is bound with the air unit (by checking the status indicators)
  - If the camera is well connected to the air unit (successful pinging through the link to the camera)
2. Check software configuration.
  - SIYI FPV App: IP addresses settings.
  - QGroundControl Apps: Video stream settings.

### **Mark**

If you have done trouble shooting by following all steps above, but there are still no clues, please contact your reseller or SIYI after-sale service.

# SIYI

## 6.10 Output Video Stream from Ground Unit

There are multiple ways to output video stream from the ground unit.

### 6.10.1 Through LAN Port

Let's take an example of outputting video stream to a Windows laptop, running Easyplayer.

1. Make sure that the ground unit is in communication with the air unit and the camera is connected.
2. Connect the ground unit's LAN port to the Windows device's RJ45 port. Then go to Ethernet settings in Windows.
3. Go to "Internet Protocol Version 4 (TCP / IPv4)" and change IP addresses as below. Then confirm.

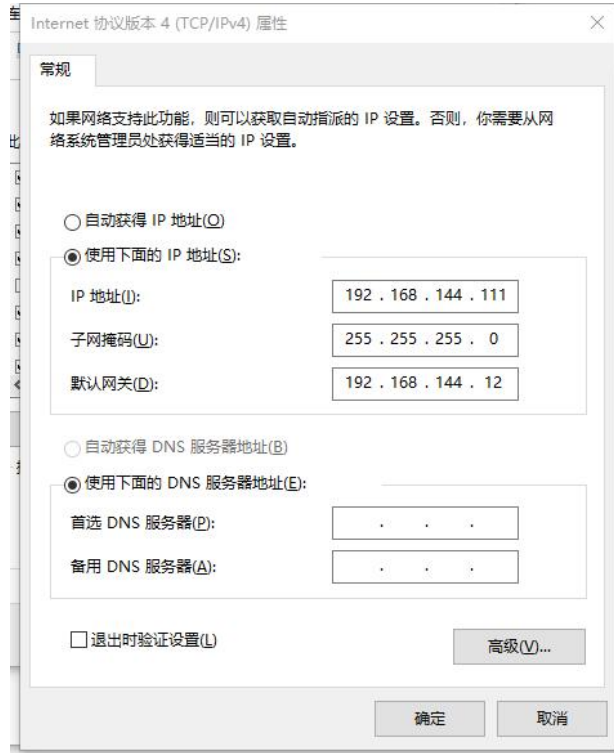

#### 4. Run Easyplayer on Windows.

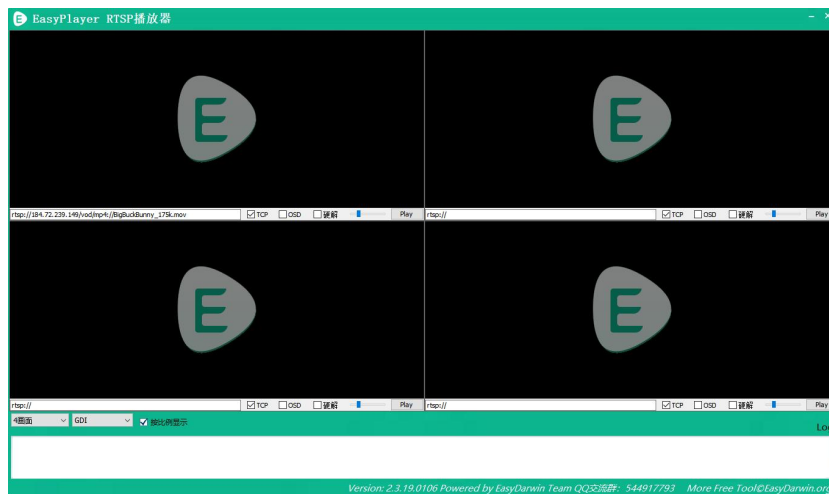

#### 5. Input the complete RTSP addresses of the connected camera or gimbal in Easyplayer to display the video stream.

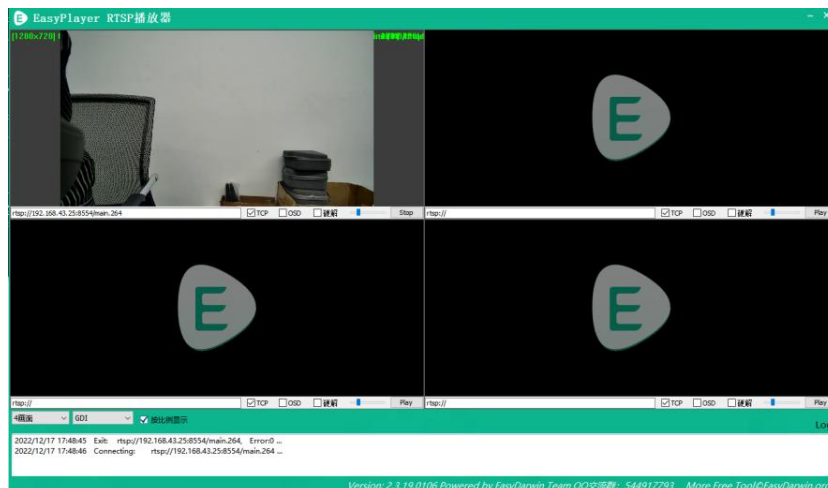

## 6.10.2 Through LAN to HDMI Output Converter

HM30 ground unit's LAN port can stream video to an HDMI monitor through the LAN to HDMI converter.



# SIYI

## Steps

1. Power both the HM30 link and the LAN to HDMI converter.
2. Then refer to the above diagram and make connection of the HM30 system, the HDMI converter, and the HDMI monitor.
3. Connection is successful if video shows up.

## CHAPTER 7 SIYI ASSISTANT

SIYI PC Assistant is a Windows software developed by SIYI to configure many SIYI products for configuration, firmware update, and calibration.

### **Mark**

The manual is edited based on SIYI PC Assistant v1.3.9.

SIYI PC Assistant and the relevant firmware pack can be downloaded from SIYI official website:

<https://siyi.biz/en/index.php?id=downloads1&asd=192>

# SIYI

## 7.1 Firmware Update

SIYI remote controller and air unit can be connected to Windows computer and be upgraded through SIYI Assistant.

Before upgrading, it is necessary to prepare the tools, software, and firmware below.

- SIYI PC Assistant (v1.3.9 or latest version)
- Ground Unit Firmware
- Air Unit Firmware

### **Mark**

Above software and firmware can be downloaded from relevant product page on SIYI official website.

- Cable (USB-C to USB-A)

### **Mark**

Above tools come with product package.

# SIYI

## Firmware Upgrade Steps

1. Install “SIYI Assistant” on your Windows device.
2. Use the upgrade cable to connect the remote controller’s upgrade port to the Windows computer’s USB port.
3. Run “SIYI Assistant” and switch to the “Upload” page to check the current firmware version of the remote controller and the air unit.

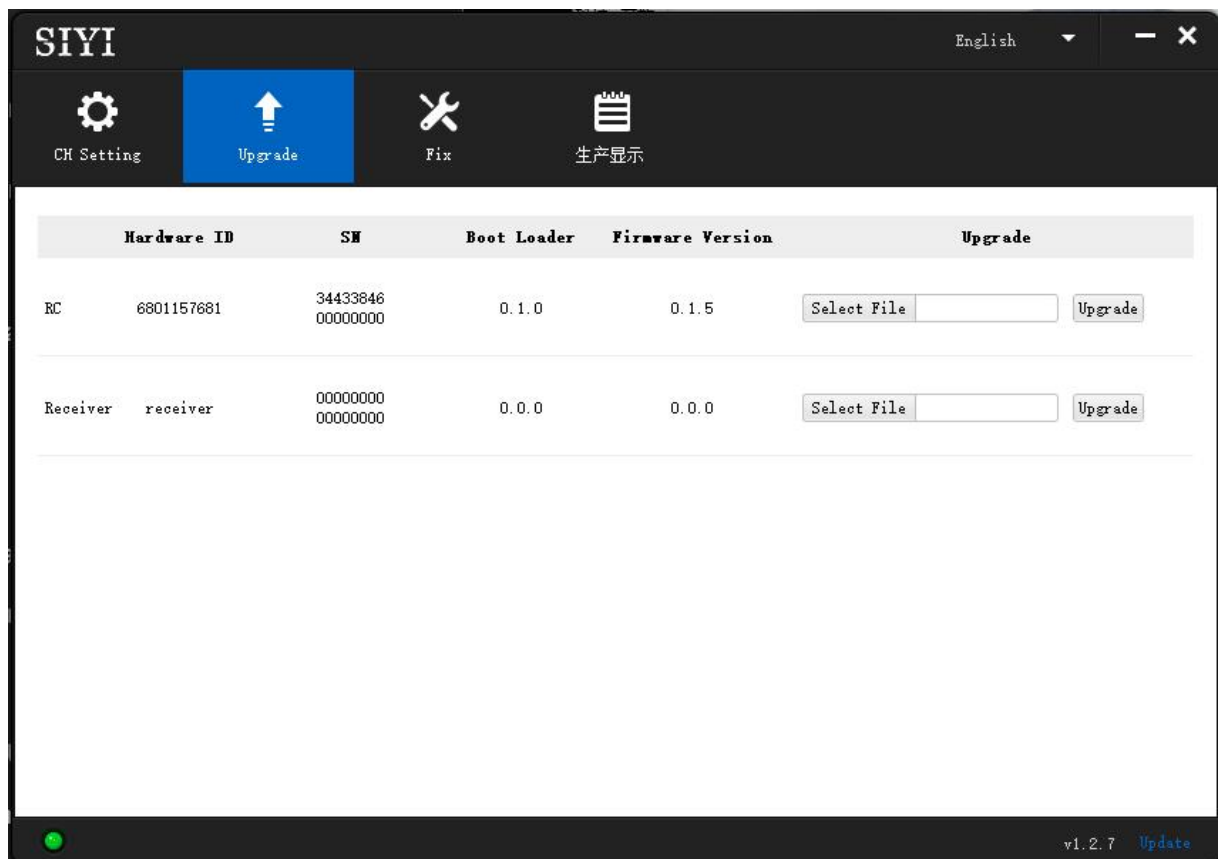

4. If the firmware is not the latest, then click the “Select File” button in the “RC” line to import the latest remote controller firmware. Then click “Upgrade” and wait till it is “100%” finished.

# SIYI

5. When updating the firmware on the air unit, please first check the first digit of the bootloader version number, then select the firmware version from the firmware package that has the same first digit for the update.
6. Disconnect the ground unit from the Windows device. Connect the air unit's Type-C port to your Windows device's USB port. Then repeat the above steps to upgrade air unit firmware.

## Mark

Please choose the correct firmware according to the initial number in the boot loader number version. For instance, if the boot loader number is 5.1.0, then please choose the firmware version starting with number 5. If the boot loader number is 0.1.0, then please choose the RF firmware version with number 0.

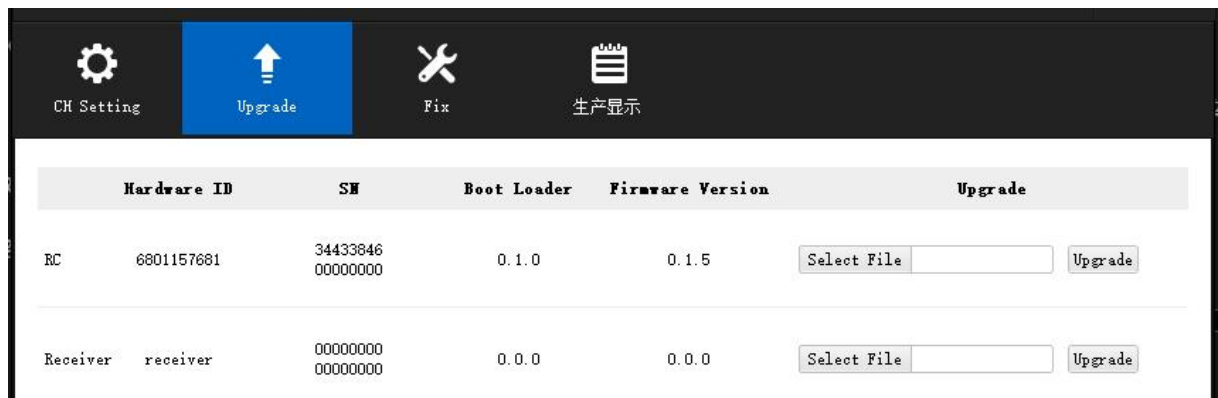

	Hardware ID	SN	Boot Loader	Firmware Version	Upgrade
RC	6801157681	34433846 00000000	0.1.0	0.1.5	Select File <input type="text"/> Upgrade
Receiver	receiver	00000000 00000000	0.0.0	0.0.0	Select File <input type="text"/> Upgrade

# SIYI

Don't worry if the ground unit firmware and the air unit firmware are different in initial numbers, they can still bind and work normally if their firmware version match.

## 7.2 Main Firmware Update Log

<b>Date</b>	2023-12-22
<b>Ground Unit Firmware</b>	0.2.3
<b>SIYI FPV App</b>	2.5.15.691
<b>Updates</b>	<ol style="list-style-type: none"><li>1. New: Be compatible with a new Bluetooth module.</li><li>2. New: SIYI datalink SDK supports UDP protocol (<b>HD-Ground must be 0.2.6 version and above</b>).</li></ol>

<b>Date</b>	2023-10-13
<b>Ground Unit Firmware</b>	0.2.2
<b>Air Unit Firmware</b>	5.3.1
<b>HD-Ground</b>	0.2.6
<b>SIYI FPV App</b>	2.5.15.678

# SIYI

<b>Updates</b>	<ol style="list-style-type: none"> <li>1. New: Support establishing UDP datalink connection in a network through ground unit's WiFi module or LAN port (<b>HD-Ground must be 0.2.6 version and above</b>).</li> <li>2. New: Support establishing UDP datalink connection with Mission Planner (<b>HD-Ground must be 0.2.6 version and above</b>).</li> <li>3. New: Support auto frequency channel change (<b>HD-Ground must be 0.2.6 version and above</b>).</li> <li>4. Improve: Manually changing frequency channel works in real-time now (<b>HD-Ground must be 0.2.6 version and above</b>).</li> <li>5. Fix: Datalink baud rate configuration sometimes did not work.</li> </ol>
----------------	---

<b>Date</b>	2023-7-12
<b>Air Unit Firmware</b>	5.2.8
<b>HD-Ground</b>	0.2.2
<b>HD-Air</b>	0.2.2
<b>Updates</b>	<ol style="list-style-type: none"> <li>1. New: HM30 air unit and MK15 air unit firmware have been merged.</li> </ol>

<b>Date</b>	2022-2-24
<b>Ground Unit Firmware</b>	0.1.9
<b>Updates</b>	<ol style="list-style-type: none"> <li>1. New: OSD type has been switched to MSP.</li> </ol>

<b>Date</b>	2022-1-10
-------------	-----------

# SIYI

<b>Ground Unit Firmware</b>	0.1.8
<b>Updates</b>	<ol style="list-style-type: none"><li>1. New: Support binding the same ground unit to multiple air units.</li><li>2. New: Release HM30 dual edition.</li><li>3. New: Air unit PWM channel configuration.</li></ol>

## 7.3 SIYI Assistant Update Log

<b>Date</b>	2024-01-06
<b>Version</b>	1.4.0
<b>Updates</b>	<ol style="list-style-type: none"><li>1. New: Support AI follow function and adjusting follow speed.</li></ol>

<b>Date</b>	2023-12-18
<b>Version</b>	1.3.9
<b>Updates</b>	<ol style="list-style-type: none"><li>1. New (ZT30, ZT6): An activation process for thermal imaging function.</li></ol>

<b>Date</b>	2023-11-02
<b>Version</b>	1.3.8 svn6958
<b>Updates</b>	<ol style="list-style-type: none"><li>2. New: Compatibility to ZT6 Mini Dual-Sensor Optical Pod.</li><li>3. New: A switch to enable zoom camera and thermal camera recording simultaneously (only in non-split-image mode and main / sub stream should be zoom / thermal camera).</li><li>4. Fix: ZT30 does not record video after setting recording resolution.</li><li>5. Fix: ZT30 does not set main stream resolution.</li></ol>

# SIYI

<b>Date</b>	2023-08-24
<b>Version</b>	1.3.7 svn6958
<b>Updates</b>	<ul style="list-style-type: none"><li>6. New: Compatibility to a new model.</li><li>7. New: Support ZT30 to switch between H265 and H264 codec.</li><li>8. Improve: Gimbal calibration function has its own page now.</li><li>9. New: Gimbal configuration (thermal synchronize zoom, thermal color palette)</li></ul>

# SIYI

## CHAPTER 8 AFTER-SALE SERVICE

Please visit the SIYI Technology support page at [Service and Support - SIYI Technology | Empowering and Building an Intelligent Robot Ecology](#) for the latest after-sales and warranty information.